

SL70 — The Monumental Thermally Broken Aluminum Framed Folding System

The SL70 is a monumentally-sized, thermally broken aluminum framed folding panel system designed to provide an opening glass wall or storefront up to 39' (12 m) wide. It is available in various configurations utilizing one to twelve panels. The running astragal design provides extra stability.

For benefits of all NanaWall systems, see the “General Introduction” section. For features common to aluminum folding systems, see the Aluminum Folding Systems Introduction section.

High Structural Performance

The system with appropriate options is engineered to provide high structural performance and weather resistance, suitable for high-rise structures and buildings. For requirements with impact glass, please look at NanaWall SL73 system.

In independent lab testing in accordance with AAMA/WDMA/CSA 101/IS.2/A440, units with panel sizes of 3' x 8', SL70 inswing with Higher weather performance sill (raised sill) achieved a DP rating of +70 psf / -100 psf, SL70 outswing with Higher weather performance sill (raised sill) and SL70 inswing/outswing with saddle sill achieved DP ratings of +/- 70 psf.

See Performance pages for results of testing of about 3' x 9'8" panel sizes.

See the Design Windload Charts on pages 11-13 for other sized panels.

High Water Resistance

In independent lab testing of static water resistance for inswing/outswing units with a Higher weather performance sill (raised sill) show no leakage at 9 psf. Dynamic water resistance test results for an inswing unit with a Higher weather performance sill (raised sill) achieved a Performance Level 2 (no leakage more than allowable at 6-18 psf) and for an outswing unit with a Higher weather performance sill (raised sill) achieved a Performance Level 1 (no leakage more than allowable at 5-15 psf).

NFRC-Approved Thermal Performance

The SL70 inswing and outswing models with all sill options have been rated, certified, and labeled in accordance with NFRC 100/200/500. With certain glass options, Energy Star U-factor, and SHGC values for some climate zones can be met. See “Performance and Testing Results” for further details.

Florida Product Approval

The SL70 system for all panel sizes and configurations is Florida statewide approved with Product Approval number FL35025. This approval includes segmented and cornerless units.

Acoustical Performance

The SL70 system has been tested by an independent acoustic lab for acoustical performance. The SL70 with recessed sill and with insulated tempered STC 32 glass achieved STC and Rw values of 33 and OITC of 27, and with STC 43 insulated laminated glass achieved STC and Rw values of 41 and OITC of 33. See Performance pages for unit acoustic values for other commonly available glass.

Life Cycle Performance

The SL70 meets the German “DIN EN 1191/12400 Classification,” where a unit is tested after 20,000 opening and closing cycles and is still functional.

Monumentally Sized Design Options

This system offers monumentally-sized panels: frame heights up to 12' 0" (3650 mm) and panel widths up to 4' are possible. See the Maximum Size Chart on Page 14 for possible maximum height and width combinations. Heavier and/or thicker glass, such as bullet-resistant laminated glazing, can also be used.

Running Post, Floor-Mounted System

This system is ideal for applications where vertical load-bearing capability of the header is a concern. The system's main weight is carried by the floor track when in the closed position. The upper-track is merely a guide. The lower-running carriages ride on top of the sill track and lie above the water run-off level. The running post design allows a floor-mounted system even with a flush sill. Stainless steel rollers ride on a stainless steel track cover.

Cornerless and Segmented Units Possible

Angled units of 90° or 135° are also possible. Segmented angles between panels of up to 6 degrees are also possible. To see these operable wall concepts in action, please visit <https://www.nanawall.com/glass-walls/folding/sl70> and click on the “Configure CAD/Revit” link.

Superior Thermal Break

The system is thermally broken with a wide polyamide plastic reinforced with glass fibers. This thermal barrier provides increased strength, superior humidity control, improved acoustics, and energy savings.

Choice of Finishes and Dual Color Option

In addition to the choices from the NanaWall Powder Coating Finish Chart, the full range of RAL high gloss, and matte powder coatings are available. Anodized and fluoropolymer kynar painted finishes are also available. The option of different finishes on the inside and outside is also available. See "Finish Options" in the General Introduction.

Hardware Options

For the main entry panel, several different locking options are available.

Swing Panel Operating Force

Operating force for opening a swing panel on the SL70 system that is installed properly with a maximum height of 10' and maximum width of 3' with double insulated glass (max. glass weight of 5 lbs/ft²) and has no door closer would be less than 5 lbs.

General Description

The SL70 is a monumentally-sized, thermally broken aluminum framed folding panel system designed to provide an opening glass wall or storefront up to 39' (12 m) wide (see Maximum Size Chart). It is available in various configurations utilizing one to twelve panels or more (see elevation drawings). The running post design provides extra stability. An option for swing entry/exit panel(s) is available; note however the further panel size constraints with a swing panel hinged from a pair(s) of folding panels. Units can be either inward or outward opening (see details in the section drawings).

Frame and Panels

The frame components are 3 1/8" (80 mm) wide (except for the saddle and flush sills that are different widths) extruded aluminum that is thermally broken with 3/4" (20 mm) wide polyamide plastic. The panels and running posts are 2 3/4" (70 mm) wide extruded aluminum that is thermally broken with a 15/16" (24 mm) wide polyamide plastic (see section drawings). In addition to the choices from the NanaWall Powder Coating Finish Chart, the full range of RAL high gloss and matte powder coatings are available. Anodized and fluoropolymer kynar painted finishes are also available. The option of different finishes on the inside and outside is also available. See "Finish Options" in the General Introduction.

The panels and running posts are pre-assembled. All pins and screws to assemble the frame are provided. Besides the higher weather performance (raised) sill, various standard aluminum flush sills (shown in section drawings) are available as an option in a clear or dark bronze anodized finish.

Glazing

Units can be supplied either glazed with 15/16" (24 mm) double insulated glass, 15/16" (24 mm) double or 1 1/2" (38 mm) triple insulated Low-E safety, other high performing safety glass such as Heat Mirror, acoustic, special tint, etc., or other glass or other thickness on request. See "Glazing" in the General Introduction section for other glass thickness possible.

Weatherstripping

All weather stripping (consisting of EPDM or brush seals) is provided for sealing between panels and between panels and frames (see section drawings).

Sliding/Folding Hardware

For sliding and folding each pair of panels, a patented, floor-supported lower running carriage is attached to the running post profile. An upper running carriage is attached as a guide (see the section drawings). The four roller lower running carriage lies above the water run-off level and is constructed to ensure even distribution of pressure on all four rollers. Rollers are stainless steel and have sealed bearings to ensure sound-free running and resistance to extreme temperature. Two to seven hinges per connection are provided to connect panels and running post profiles together and to connect panels to the frame. Finish of standard zinc die cast hinges would be closest powder coat match to panel profile. Available as an option are stainless steel hinges.

Locking Hardware and Handle Options

For each pair of folding panels (except for the pair to be opened first in a unit with no swing panel) provided is two-point locking hardware consisting of top and bottom Polyamide capped locking rods operated by a 180° turn of a handle on the inside only. If there is a swing panel, there are the following hardware options on the main entry panel:

1. Multi-point Locking. Consisting of lever handles on both sides, a lockset, lockable latch, deadbolt, and rods at the top and the bottom. After turn of key or thumbturn, depression of handles withdraws latch, lifting of handles engages rods, and turn of key or thumbturn engages deadbolt and locks. For a unit with a secondary swing panel available are matching dummy lever handles on both sides and concealed flush bolts that operate the rods at the top and the bottom. Available with European profile cylinder or an adapter to accommodate a 5-7 pin SFIC core (SFIC core supplied by others). Locking is independently tested for acoustics, structural, air, water, and forced entry.

2. Deadbolt Lock and one-point locking at the top and bottom. Consisting of push/pull handles on both sides with deadbolt(s) operated by a lockset. Turn of key or thumb turn operates lock. Available is a lockset option of having key operation on both sides. One-point locking consists of Polyamide capped locking rods operated by a 180° turn of a flat handle on the inside at the top and bottom. To keep the panel closed when locking points are disengaged, a door closer by others should be field installed, but note that a door closer can only be installed to a swing panel that is attached to the side jamb.

3. Single Action, Emergency Access, Interconnected Locking. Consisting of special lever handles on both sides, a lockset, a lockable latch, and a deadbolt. From the inside,

depression of handle withdraws deadbolt and latch. The one-point locking is sufficient for interior use.

To meet wind load requirements for exterior use during high wind conditions, additional one-point locks operated by separate handles can be provided at the top and bottom. In severe storm conditions, these can be engaged; however, the locking no longer qualifies for emergency access during this instance.

4. No Hardware. For panic hardware to be prepped, supplied, and installed by others, the main entry panel can be supplied with no locking hardware. Please note that with this option, the structural design windloads for the unit will no longer be valid.

For a unit with **no swing panel**, on the folding pair is to be opened first: Two-point locking hardware consisting of top and bottom Polyamide capped locking rods operated by a 180° turn of handles on both sides. Lockable with a lockset. Turn of key or thumb turn operates lock.

For a unit where locking/handles inside only is desired, like in window applications, on all swing panels or pair of folding panels to be opened first, provided is two-point locking with a handle on the inside only.

Handle Finish Schemes:







Standard - Stainless steel lever, standard, and L-shaped handles in brushed satin or black titanium finish.

Optional - Brass lever handles in oil rubbed, satin nickel, or white finish.

Push/pull handles are available in brushed stainless steel.

Higher Weather Performance (Raised) Sill

SL70

TYPE OF TEST	INWARD OPENING UNITS	OUTWARD OPENING UNITS	
 Air Infiltration ASTM E-283 and NFRC 400, cfm/ft ²	@ 1.57 psf (75 Pa): 0.16 ^③ (0.02 exfiltration) A2 ^②	@ 1.57 psf (75 Pa): 0.02 ^③ (0.03 exfiltration) A3 ^②	
	@ 6.24 psf (300 Pa): 0.20	@ 6.24 psf (300 Pa): 0.08	
 Static Water Penetration* ASTM E-547/E-331	No uncontrolled water entry ^③ @ 9 psf (440 Pa)	No uncontrolled water entry ^③ @ 9 psf (440 Pa)	
 Structural Load Deflection TAS 202 & ASTM E-330: pass See design windload charts for other sized panels <i>Note that the structural test pressures were 50% higher than the design pressures.</i>	8 FOOT TALL ^①	8 FOOT TALL ^①	
	DESIGN PRESSURE		
	Positive @ 70 psf (3350 Pa)	Negative @ 100 psf (4785 Pa)	Positive @ 70 psf (3350 Pa)
	Class SP-PG60, Panel size - 3' x 8' (915 mm x 2438 mm) ^②		Negative @ 70 psf (3350 Pa)
Class SP-PG60, Panel size - 3' x 8' (915 mm x 2438 mm) ^②		Class SP-PG60, Panel size - 3' x 8' (915 mm x 2438 mm) ^②	
10 FOOT TALL ^③		10 FOOT TALL ^③	
DESIGN PRESSURE ^②		DESIGN PRESSURE ^②	
Positive @ 45 psf (2160 Pa)	Negative @ 70 psf (3350 Pa)	Positive @ 70 psf (3350 Pa)	Negative @ 45 psf (2160 Pa)
Class SP-PG45 Panel size - 2' 11" x 9' 9" (905 mm x 2965 mm) ^②		Class SP-PG45 Panel size - 2' 11" x 9' 9" (905 mm x 2965 mm) ^②	
Class SP-PG45 Panel size - 2' 11" x 9' 9" (905 mm x 2965 mm) ^②		Class SP-PG45 Panel size - 2' 11" x 9' 9" (905 mm x 2965 mm) ^②	
 Dynamic Water Penetration ^① AAMA 520 & ASTM E-2268	Performance level 2: No water entry more than allowable @ 6-18 psf (300-860 Pa)	Performance level 1: No water entry more than allowable @ 5-15 psf (250-715 Pa)	
 Life Cycle Performance	The SL70 meets the German "DIN EN 1191/12400 Classification," where a unit is tested after 20,000 opening and closing cycles and is still functional.		
 Forced Entry Resistance ^{①③}	In accordance with AAMA-1304 and ASTM F842 requirements		

① Excerpts of results of 3 separate units of various panels and configurations tested by Architectural Testing, Inc., Fresno, CA, an independent testing laboratory in October 2009 per various fenestration test standards.

② For Canada, tested to NAFS-08 or equivalent and CSA A44051-09 (with weep holes in sill by others to drain standing water in sill channels).

③ Excerpts of results of a 13' 1" W x 10' H (4000 mm x 3050 mm) four panel unit tested by Architectural Testing, Inc., Fresno, CA, an independent testing laboratory, in October 2015 per AAMA/WDMA/CSA 101/1.S.2/A440, NAFS - North American Fenestration Standard

* Water rating may not be applicable for configuration not tested, especially even panels and even panels configurations.

Higher Weather Performance (Raised) Sill

SL70



Thermal Performance

Rated, certified and labeled in accordance with NFRC 100 + 200

TYPE OF GLASS (1 LITE) ^④	CENTER OF GLASS U-FACTOR	INWARD OPENING UNITS				OUTWARD OPENING UNITS			
		UNIT U-FACTOR	SHGC ^⑤	VT ^⑥	2015 ENERGY STAR	UNIT U-FACTOR	SHGC ^⑤	VT ^⑥	2015 ENERGY STAR
Double IG Clear (air filled)	.48	.50	.52	.53	-	.51	.52	.53	-
Double IG Low E (argon filled)	.26	.36	.19	.41	-	.37	.19	.41	-
Double IG Low E (air filled)	.30	.39	.19	.41	-	.40	.19	.41	-
Double IG Low E #2 & #4 surfaces (argon filled)	.21	.33	.18	.40	-	.34	.18	.40	-
Double IG Low E #2 & #4 surfaces (air filled)	.24	.35	.18	.40	-	.36	.18	.40	-
Triple IG Low E x 2 (argon filled)	.13	.27	.16	.29	*	.28	.16	.29	*
Triple IG Low E x 2 (air filled)	.13	.29	.16	.29	*	.30	.16	.29	*
Triple IG Alternate Higher SHGC Low E x 2 (argon filled)	.15	.27	.24	.38	*	.28	.24	.38	*
Triple IG Alternate Higher SHGC Low E x 2 (air filled)	.17	.29	.24	.38	*	.30	.24	.38	*

NOTES

④ NFRC simulated U factors of units with a horizontal mullion will have values of .01 to .02 higher than units with no horizontal mullion. Please contact NanaWall for details.

⑤ SHGC = Solar Heat Gain Coefficient
⑥ VT = Visible Transmittance

* 2015 Energy Star Qualification Criteria: U-Factor for doors in all climate zones ≤.30, SHGC ≤.25 in South/South Central zones and ≤.40 in North/North Central zones. (For guidance only. NanaWall is not a participant of the Energy Star program.)

Shown above are thermal values for select glass options only. Thermal values for many other glass options are available. These may be able to meet specific requirements, such as Energy Star values for other zones, CA Title 24 prescriptive values, other state and local energy codes, etc. Thermal values for glass with other Low E coatings and Suntuitive dynamic glass are available. Please contact NanaWall for more information.

Low Profile Saddle Sill

SL70

TYPE OF TEST	INWARD OPENING UNITS	OUTWARD OPENING UNITS																																
 <p>Air Infiltration ^④ ASTM E-283 and NFRC 400, cfm/ft²</p>	<p>@ 1.57 psf (75 Pa): 0.15 (0.14 exfiltration) A2 ^②</p> <p>@ 6.24 psf (300 Pa): 0.29</p>	<p>@ 1.57 psf (75 Pa): 0.14 (0.15 exfiltration) A2 ^②</p> <p>@ 6.24 psf (300 Pa): 0.30</p>																																
 <p>Static Water Penetration ^{①④} ASTM E-547/E-331</p>	<p>Unit with weep holes from middle channel: No uncontrolled water entry @ 2.1 psf (100 Pa)</p> <p>Subject to the following adaptations of the sill in the field by others: 1. Remove the gasket covering the middle channel 2. Drill weep holes through the outer bottom wall in middle channel (3/8" weep hole per panel) 3. Drill weep holes through the lower front face of sill (3/8" weep hole per panel)</p> <hr/> <p>Unit with weep holes from inner channel: No uncontrolled water entry @ 5.25 psf (250 Pa)</p> <p>Subject to the following adaptations of the sill in the field by others: 1. Remove the gaskets covering the inner channel. 2. Drill weep holes through the bottom of this channel (about one 3/8" weep hole per panel.) 3. Drill weep holes through the lower front face of the sill to the inner channel bottom (about 3/8" weep hole per panel.)</p> <p>Please note that due to varying site requirements and conditions, these sills will not be prepared for drainage by NanaWall Systems, Inc. If this drainage system is desired, we recommend that a qualified professional construct this system on the project site that is strictly in accordance with instructions provided by NanaWall Systems, Inc. and in accordance with good waterproofing techniques. If drain connections are not made, or are not possible, unit may leak with wind driven rain.</p>																																	
 <p>Structural Load Deflection TAS 202 & ASTM E-330: pass See design windload charts for other sized panels <i>Note that the structural test pressures were 50% higher than the design pressures.</i></p>	<table border="1"> <thead> <tr> <th colspan="2" data-bbox="671 1016 965 1054">8 FOOT TALL ^①</th> <th colspan="2" data-bbox="965 1016 1254 1054">8 FOOT TALL ^①</th> </tr> <tr> <th colspan="2" data-bbox="671 1054 965 1087">DESIGN PRESSURE</th> <th colspan="2" data-bbox="965 1054 1254 1087">DESIGN PRESSURE</th> </tr> </thead> <tbody> <tr> <td data-bbox="671 1087 813 1192">Positive @ 70 psf (3350 Pa)</td> <td data-bbox="813 1087 965 1192">Negative @ 70 psf (3350 Pa)</td> <td data-bbox="965 1087 1107 1192">Positive @ 70 psf (3350 Pa)</td> <td data-bbox="1107 1087 1254 1192">Negative @ 70 psf (3350 Pa)</td> </tr> <tr> <td colspan="2" data-bbox="671 1192 965 1255">Class SP-PG35 Panel size - 3' x 8' (915 mm x 2438 mm) ^② (weep holes by others)</td> <td colspan="2" data-bbox="965 1192 1254 1255">Class SP-PG35 Panel size - 3' x 8' (915 mm x 2438 mm) ^② (weep holes by others)</td> </tr> <tr> <th colspan="2" data-bbox="671 1255 965 1289">10 FOOT TALL ^④</th> <th colspan="2" data-bbox="965 1255 1254 1289">10 FOOT TALL ^④</th> </tr> <tr> <th colspan="2" data-bbox="671 1289 965 1323">DESIGN PRESSURE</th> <th colspan="2" data-bbox="965 1289 1254 1323">DESIGN PRESSURE</th> </tr> <tr> <td data-bbox="671 1323 813 1428">Positive @ 45 psf (2160 Pa)</td> <td data-bbox="813 1323 965 1428">Negative @ 55 psf (2640 Pa)</td> <td data-bbox="965 1323 1107 1428">Positive @ 55 psf (2640 Pa)</td> <td data-bbox="1107 1323 1254 1428">Negative @ 45 psf (2160 Pa)</td> </tr> <tr> <td colspan="2" data-bbox="671 1428 965 1509">For saddle sill specimen #2 above, Class SP-PG35, Panel size - 2' 11" x 9' 8" (905 mm x 2950 mm) ^② (weep holes by others)</td> <td colspan="2" data-bbox="965 1428 1254 1509">For saddle sill specimen #2 above, Class SP-PG35, Panel size - 2' 11" x 9' 8" (905 mm x 2950 mm) ^② (weep holes by others)</td> </tr> </tbody> </table>		8 FOOT TALL ^①		8 FOOT TALL ^①		DESIGN PRESSURE		DESIGN PRESSURE		Positive @ 70 psf (3350 Pa)	Negative @ 70 psf (3350 Pa)	Positive @ 70 psf (3350 Pa)	Negative @ 70 psf (3350 Pa)	Class SP-PG35 Panel size - 3' x 8' (915 mm x 2438 mm) ^② (weep holes by others)		Class SP-PG35 Panel size - 3' x 8' (915 mm x 2438 mm) ^② (weep holes by others)		10 FOOT TALL ^④		10 FOOT TALL ^④		DESIGN PRESSURE		DESIGN PRESSURE		Positive @ 45 psf (2160 Pa)	Negative @ 55 psf (2640 Pa)	Positive @ 55 psf (2640 Pa)	Negative @ 45 psf (2160 Pa)	For saddle sill specimen #2 above, Class SP-PG35, Panel size - 2' 11" x 9' 8" (905 mm x 2950 mm) ^② (weep holes by others)		For saddle sill specimen #2 above, Class SP-PG35, Panel size - 2' 11" x 9' 8" (905 mm x 2950 mm) ^② (weep holes by others)	
8 FOOT TALL ^①		8 FOOT TALL ^①																																
DESIGN PRESSURE		DESIGN PRESSURE																																
Positive @ 70 psf (3350 Pa)	Negative @ 70 psf (3350 Pa)	Positive @ 70 psf (3350 Pa)	Negative @ 70 psf (3350 Pa)																															
Class SP-PG35 Panel size - 3' x 8' (915 mm x 2438 mm) ^② (weep holes by others)		Class SP-PG35 Panel size - 3' x 8' (915 mm x 2438 mm) ^② (weep holes by others)																																
10 FOOT TALL ^④		10 FOOT TALL ^④																																
DESIGN PRESSURE		DESIGN PRESSURE																																
Positive @ 45 psf (2160 Pa)	Negative @ 55 psf (2640 Pa)	Positive @ 55 psf (2640 Pa)	Negative @ 45 psf (2160 Pa)																															
For saddle sill specimen #2 above, Class SP-PG35, Panel size - 2' 11" x 9' 8" (905 mm x 2950 mm) ^② (weep holes by others)		For saddle sill specimen #2 above, Class SP-PG35, Panel size - 2' 11" x 9' 8" (905 mm x 2950 mm) ^② (weep holes by others)																																
 <p>Life Cycle Performance</p>	<p>The SL70 meets the German "DIN EN 1191/12400 Classification," where a unit is tested after 20,000 opening and closing cycles and is still functional.</p>																																	
 <p>Operation / Cycling Performance ^③ AAMA 920</p>	<p>For swing panel attached to side jamb: 500,000 cycles - pass</p>																																	
 <p>Forced Entry Resistance ^{①④}</p>	<p>In accordance with AAMA-1304 and ASTM F842 requirements</p>																																	

① Excerpts of results of a 12' 9 15/16" W x 8' 3 7/8" H four panel unit tested by Architectural Testing, Inc., Fresno, CA, an independent testing laboratory, in October 2009.

② For Canada, tested to NAFS-08 or equivalent and CSA A44051-09 (with weep holes in sill by others).

③ Excerpts of results of a system tested by Architectural Testing, Inc., Fresno, CA, an independent testing laboratory, in April 2013.

④ Excerpts of results of a 13' 1" W x 10' H (4000 mm x 3050 mm) four panel unit tested by Architectural Testing, Inc., Fresno, CA, an independent testing laboratory, in October 2015 per AAMA/WDMA/CSA 101/1S.2/A440, NAFS - North American Fenestration Standard

Low Profile Saddle Sill SL70



Thermal Performance

Rated, certified and labeled in accordance with NFRC 100 + 200

TYPE OF GLASS (1 LITE) ^⑤	CENTER OF GLASS U-FACTOR	INWARD OPENING				OUTWARD OPENING			
		UNIT U-FACTOR	SHGC ^⑥	VT ^⑦	2015 ENERGY STAR	UNIT U-FACTOR	SHGC ^⑥	VT ^⑦	2015 ENERGY STAR
Double IG Clear (air filled)	.48	.51	.51	.52	-	.52	.52	.54	-
Double IG Low E (argon filled)	.26	.36	.19	.41	-	.37	.19	.41	-
Double IG Low E (air filled)	.30	.40	.19	.41	-	.40	.19	.41	-
Double IG Low E #2 & #4 surfaces (argon filled)	.21	.33	.18	.40	-	.34	.18	.40	-
Double IG Low E #2 & #4 surfaces (air filled)	.24	.35	.19	.40	-	.36	.18	.40	-
Triple IG Low E x 2 (argon filled)	.13	.28	.16	.29	*	.28	.16	.29	*
Triple IG Low E x 2 (air filled)	.13	.30	.16	.29	*	.30	.16	.29	*
Triple IG Alternate Higher SHGC Low E x 2 (argon filled)	.15	.28	.24	.39	*	.28	.24	.39	*
Triple IG Alternate Higher SHGC Low E x 2 (air filled)	.17	.30	.24	.39	*	.31	.24	.39	-

NOTES





⑤ NFRC simulated U factors of units with a horizontal mullion will have values of .01 to .02 higher than units with no horizontal mullion. Please contact NanaWall for details.

⑥ SHGC = Solar Heat Gain Coefficient
⑦ VT = Visible Transmittance

* 2015 Energy Star Qualification Criteria: U-Factor for doors in all climate zones ≤ 30 , SHGC ≤ 25 in South/South Central zones and ≤ 40 in North/North Central zones. (For guidance only. NanaWall is not a participant of the Energy Star program.)

Shown above are thermal values for select glass options only. Thermal values for many other glass options are available. These may be to meet specific requirements, such as Energy Star values for other zones, CA Title 24 prescriptive values, other state and local energy codes, etc. Thermal values for glass with other Low E coating and Suntuitive dynamic glass are available. Please contact NanaWall for more information.

Flush Sill SL70

TYPE OF TEST	INWARD OPENING UNITS	OUTWARD OPENING UNITS (based on inward opening testing)	
 Air Infiltration ^② ASTM E-283 and NFRC 400, cfm/ft ²	@ 1.57 psf (75 Pa): 0.15 (0.14 exfiltration) A2	@ 1.57 psf (75 Pa): 0.14 (0.15 exfiltration) A2	
	@ 6.24 psf (300 Pa): 0.29	@ 6.24 psf (300 Pa): 0.30	
 Structural Load Deflection ASTM E-330: pass See design windload charts for other sized panels <i>Note that the structural test pressures were 50% higher than the design pressures.</i>	8 FOOT TALL ^①		
	DESIGN PRESSURE ^②		
	Positive @ 70 psf (3350 Pa)	Negative @ 70 psf (3350 Pa)	Positive @ 70 psf (3350 Pa)
	Negative @ 70 psf (3350 Pa)	Positive @ 70 psf (3350 Pa)	Negative @ 70 psf (3350 Pa)
10 FOOT TALL ^②		10 FOOT TALL ^②	
DESIGN PRESSURE ^②		DESIGN PRESSURE ^②	
Positive @ 45 psf (2160 Pa)	Negative @ 55 psf (2640 Pa)	Positive @ 55 psf (2640 Pa)	
Negative @ 55 psf (2640 Pa)	Positive @ 45 psf (2160 Pa)	Negative @ 45 psf (2160 Pa)	
 Life Cycle Performance	The SL70 meets the German "DIN EN 1191/12400 Classification," where a unit is tested after 20,000 opening and closing cycles and is still functional.		
 Forced Entry Resistance ^{①②}	In accordance with AAMA-1304 and ASTM F842 requirements		

① Excerpts of results of a 12' 9 15/16" W x 8' 3 7/8" H four panel unit tested by Architectural Testing, Inc., Fresno, CA, an independent testing laboratory, in October 2009.

② Excerpts of results of a 13' 1" W x 10' H (4000 mm x 3050 mm) four panel unit tested by Architectural Testing, Inc., Fresno, CA, an independent testing laboratory, in October 2015 per AAMA/WDMA/CSA 101/1.S.2/A440, NAFS - North American Fenestration Standard

Flush Sill

SL70



Thermal Performance

Rated, certified and labeled in accordance with NFRC 100 + 200

TYPE OF GLASS (1 LITE) ^③	CENTER OF GLASS U-FACTOR	INWARD OPENING				OUTWARD OPENING			
		UNIT U-FACTOR	SHGC ^④	VT ^⑤	2015 ENERGY STAR	UNIT U-FACTOR	SHGC ^④	VT ^⑤	2015 ENERGY STAR
Double IG Clear (air filled)	.48	.51	.53	.54	-	.51	.52	.54	-
Double IG Low E (argon filled)	.26	.36	.19	.42	-	.37	.19	.42	-
Double IG Low E (air filled)	.30	.39	.19	.42	-	.40	.19	.42	-
Double IG Low E #2 & #4 surfaces (argon filled)	.21	.33	.18	.40	-	.34	.18	.40	-
Double IG Low E #2 & #4 surfaces (air filled)	.24	.35	.19	.40	-	.36	.18	.40	-
Triple IG Low E x 2 (argon filled)	.13	.27	.17	.29	*	.28	.16	.29	*
Triple IG Low E x 2 (air filled)	.16	.29	.17	.29	*	.30	.16	.29	*
Triple IG Alternate Higher SHGC Low E x 2 (argon filled)	.15	.27	.24	.39	*	.28	.24	.39	*
Triple IG Alternate Higher SHGC Low E x 2 (air filled)	.17	.29	.24	.39	*	.30	.24	.39	*

NOTES

③ NFRC simulated U factors of units with a horizontal mullion will have values of .01 to .02 higher than units with no horizontal mullion. Please contact NanaWall for details.

④ SHGC = Solar Heat Gain Coefficient
⑤ VT = Visible Transmittance

* 2015 Energy Star Qualification Criteria: U-Factor for doors in all climate zones ≤.30, SHGC ≤.25 in South/South Central zones and ≤.40 in North/North Central zones. (For guidance only. NanaWall is not a participant of the Energy Star program.)

Shown above are thermal values for select glass options only. Thermal values for many other glass options are available. These may be able to meet specific requirements, such as Energy Star values for other zones, CA Title 24 prescriptive values, other state and local energy codes, etc. Thermal values for glass with other Low E coatings and Suntuitive dynamic glass are available. Please contact NanaWall for more information.

SL70

TYPE OF TEST	RESULTS
 Acoustical Performance ^①	STC (Rw) 33 and OITC 27 achieved with STC 32 glass (15/16" [24 mm] double IGU, 4 mm tempered + 4 mm tempered)
	STC (Rw) 41 and OITC 33 achieved with STC 43 glass (1 7/16" [36 mm] double IGU, 8 mm laminated + 6 mm tempered)
	STC (Rw) 43 and OITC 35 achieved with STC 48 glass (1 1/2" [38 mm] double IGU, 10 mm laminated + 8 mm laminated)

① Excerpts of results of a three panel unit 9' 10" W x 8' 2" H (3000 mm x 2500 mm) tested in August 2019 by SG Bauakustik, Muelheim an der Ruhr, Germany, an EN DIN ISO accredited and certified independent testing laboratory.

Check www.NanaWall.com for the latest updates.

Acoustical Performance Interpolation with Other Glazing Options

TYPE OF GLASS	GLASS ONLY STC	FLUSH SILL	
		COMPLETE SYSTEM STC (Rw)	MAXIMUM UNIT HEIGHT POSSIBLE
1/4" (6 mm) tempered	31	32	12' 0" (3650 mm)
1/4" (6 mm) laminated	35	35	12' 0" (3650 mm)
1/4" (6 mm) enhanced laminated	36	36	12' 0" (3650 mm)
1/2" (12 mm) enhanced laminated	39	38	10' 2" (3100 mm)
1 5/16" (34 mm) double IGU, 6 mm enhanced laminated + 6 mm enhanced laminated	44	42	10' 2" (3100 mm)

Contact NanaWall for other glass types.

**Applies to Negative Design Pressures for Inswing Units and Positive Design Pressures for Outswing Units with the Higher Weather Performance Sill
(In Accordance with Allowable Stress Design (ASD) Design Pressures*)**

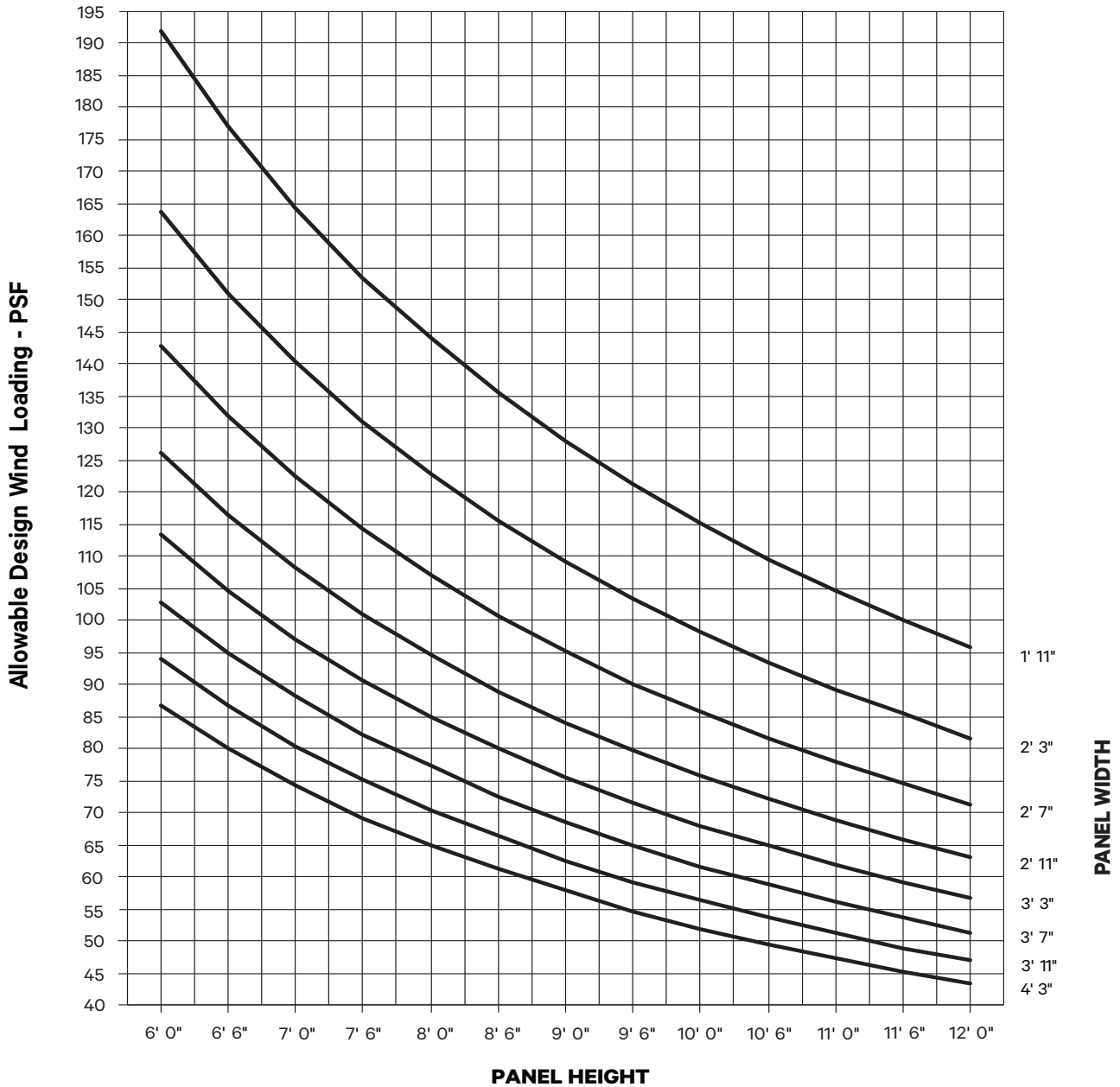

Any Custom Size is Possible. See Maximum Frame Size Chart for Maximum Possible Size.

(Derived from Comparative Analysis) Test Panel Size: 3' 0" W x 9' 8" H.

Please note that some jurisdictions may limit the use of these charts or may not accept them at all. Design pressures and/or sizes may be restricted to what was tested. For Florida approved products, please see detailed FL Evaluation Report for restrictions. This chart is only applicable for units with referenced NanaWall supplied locking.

* If the project design pressures have been calculated in accordance with Ultimate Design Wind Speed (ULT), then these design pressures have to be multiplied by a factor of 0.6 to obtain the equivalent ASD design pressures shown in this chart.

**Applies to Positive Design Pressures for Inswing Units and Negative Design Pressures for Outswing Units with the Higher Weather Performance, Low Profile Saddle, and Flush Sill
(In Accordance with Allowable Stress Design (ASD) Design Pressures*)**

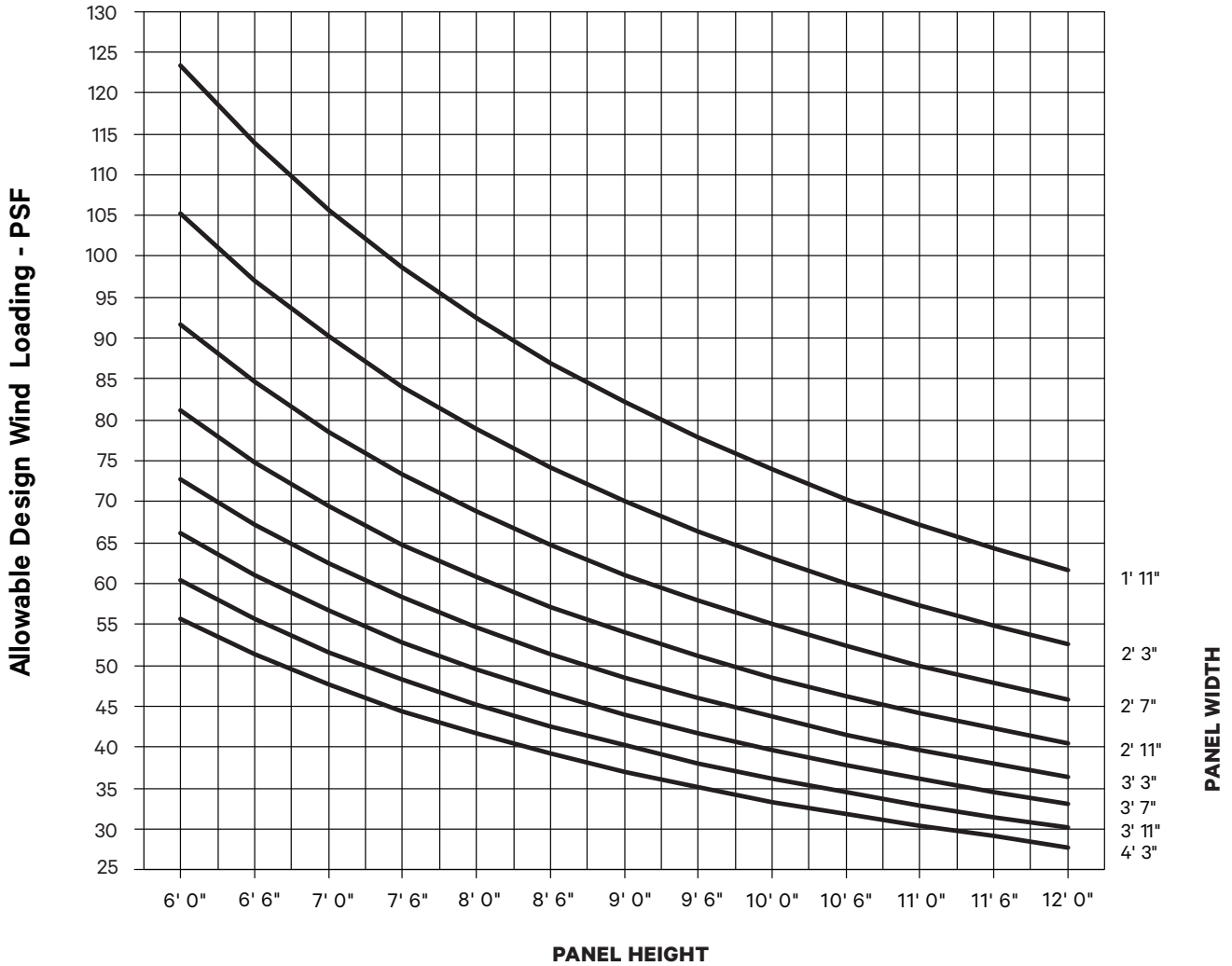

Any Custom Size is Possible. See Maximum Frame Size Chart for Maximum Possible Sizes.

(Derived from Comparative Analysis) Test Panel Size: 3' 0" W x 9' 8" H

Please note that some jurisdictions may limit the use of these charts or may not accept them at all. Design pressures and/or sizes may be restricted to what was tested. For Florida approved products, please see detailed FL Evaluation Report for restrictions. This chart is only applicable for units with referenced NanaWall supplied locking.

* If the project design pressures have been calculated in accordance with Ultimate Design Wind Speed (ULT), then these design pressures have to be multiplied by a factor of 0.6 to obtain the equivalent ASD design pressures shown in this chart.

**Applies to Negative Design Pressures for Inswing Units and Positive Design Pressures for Outswing Units with the Low Profile Saddle and Flush Sill
(In Accordance with Allowable Stress Design (ASD) Design Pressures*)**

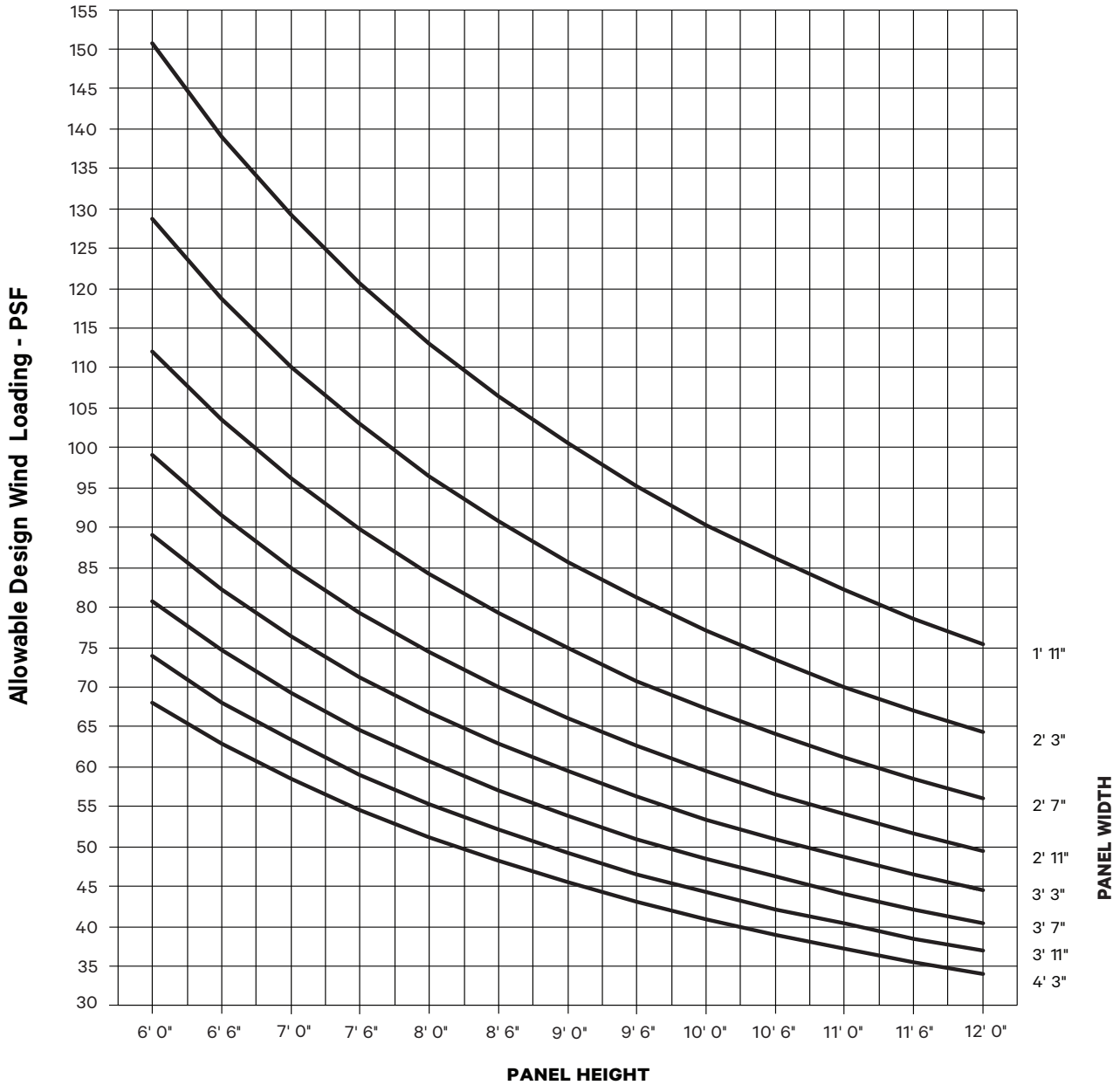

Any Custom Size is Possible. See Maximum Frame Size Chart for Maximum Possible Sizes.

(Derived from Comparative Analysis) Test Panel Size: 3' 0" W x 9' 8" H

Please note that some jurisdictions may limit the use of these charts or may not accept them at all. Design pressures and/or sizes may be restricted to what was tested. For Florida approved products, please see detailed FL Evaluation Report for restrictions. This chart is only applicable for units with referenced NanaWall supplied locking.

* If the project design pressures have been calculated in accordance with Ultimate Design Wind Speed (ULT), then these design pressures have to be multiplied by a factor of 0.6 to obtain the equivalent ASD design pressures shown in this chart.

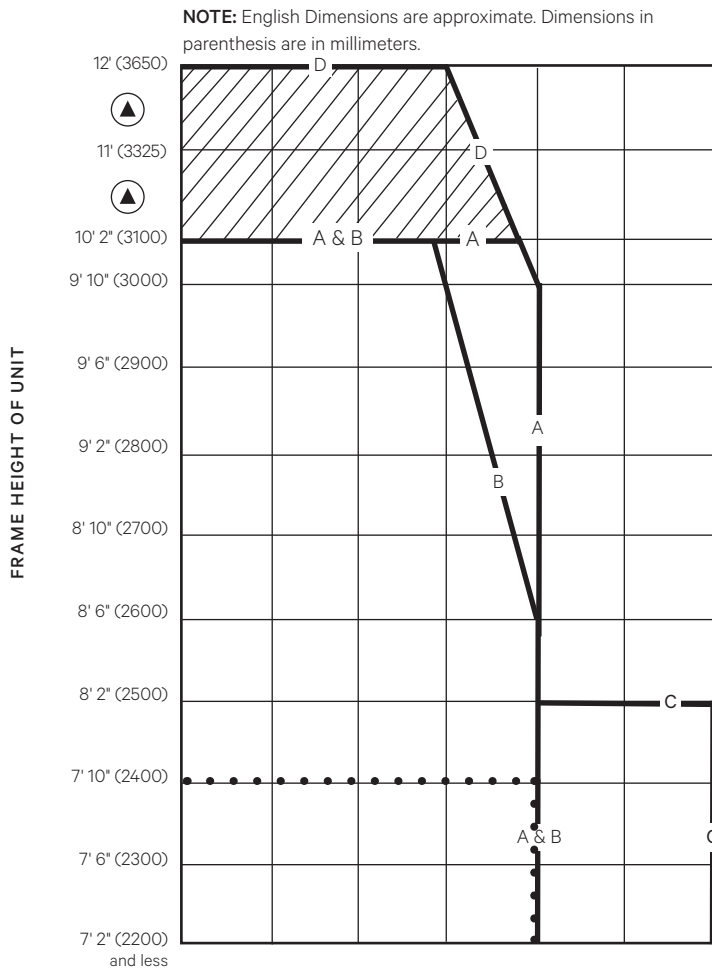

NUMBER OF PANELS IN UNIT	FRAME WIDTH OF UNIT						
	1' 11" (600)	2' 3" (700)	2' 7" (800)	2' 11" (900)	3' 3" (1000)	widths not possible	widths not possible
2	3' 11" (1200)	4' 7" (1400)	5' 3" (1600)	5' 10" (1800)	6' 6" (2000)	7' 2" (2200)	8' 0" (2440)
3	5' 10" (1800)	6' 10" (2100)	7' 10" (2400)	8' 10" (2700)	9' 10" (3000)	widths not possible	widths not possible
4	7' 10" (2400)	9' 2" (2500)	10' 6" (3200)	11' 9" (3600)	13' 1" (4000)	14' 5" (4400)	16' 0" (4875)
5	9' 10" (3000)	11' 5" (3500)	13' 1" (4000)	14' 9" (4500)	16' 4" (5000)	widths not possible	widths not possible
6	11' 9" (3600)	13' 10" (4200)	15' 8" (4800)	17' 8" (5400)	19' 8" (6000)	21' 7" (6600)	24' 0" (7320)
7	13' 10" (4200)	16' (4900)	18' 4" (5600)	20' 7" (6300)	22' 10" (7000)	widths not possible	widths not possible
8	15' 8" (4800)	18' 4" (5600)	20' 11" (6400)	23' 6" (7200)	26' 1" (8000)	28' 10" (8800)	32' 0" (9750)
9	17' 9" (5400)	20' 7" (6300)	23' 6" (7200)	26' 5" (8100)	29' 4" (9000)	widths not possible	widths not possible
10	19' 8" (6000)	22' 10" (7000)	26' 1" (8000)	29' 4" (9000)	32' 9" (10000)	widths not possible	widths not possible
11	21' 7" (6600)	25' 1" (7700)	28' 8" (8800)	32' 5" (9900)	36' 1" (11000)	widths not possible	widths not possible
12	23' 6" (7200)	27' 4" (8400)	31' 5" (9600)	35' 5" (10800)	39' 4" (12000)	widths not possible	widths not possible

Up to twelve panels are possible in a unit. Any custom panel size is possible up to the maximum size shown.

A, B, C & D: Solid dark line on chart indicates maximum frame height possible for a given maximum frame width.

On chart indicates need of a horizontal mullion in each panel such that no individual glass height is more than 7' 10" (2400 mm).

Dotted line on chart indicates that for units with triple glazing, a horizontal mullion is needed for sizes beyond this line.

For segmented units, a horizontal mullion is needed for all heights more than 8' 4" (2550 mm).

Indicates height increase.

A. For configurations with a swing panel hinged to a side jamb combined with a pair(s) of folding panels or for configurations with a pair(s) of folding panels only - includes Models 1L, 1R, 1L1R, 1L2R, 1L4R, 1L6R, 2L, 2R, 2L1R, 2L2R, 2L4R, 2L6R, 4R, 4L, 4L1R, 4L2R, 4L4R, 4L6R, 6R, 6L, 6L1R, 6L2R, 6L4R, 6L6R.

B. For all configurations.

C. On chart indicates possible only in the following configurations: 2L, 2R, 4L, 4R, 2L2R, 2L4R, 4L2R, 4L4R, 4L6R, 6L, 6R, 6L4R, and 6L6R. (Not possible with triple glazing.)

D. On chart indicates possible only in the following configurations: 2L, 2R, 4L, 4R, 2L2R, 2L4R, 4L2R, and 4L4R. Possible with higher weather performance sill (raised sill) only.

Please note that the bigger size panels (especially tall panels) may need to be operated by more than one person.

For configurations with no swing panels, the minimum panel width needed is 2' 3" (700 mm).

The maximum size limits shown are based on the weight of a panel that has a net glass thickness of not more than 3/8" (10 mm). For larger net glass thickness, this maximum size limit chart will not apply.

Interior Size Chart SL70: UNIT STC 32 to STC 36

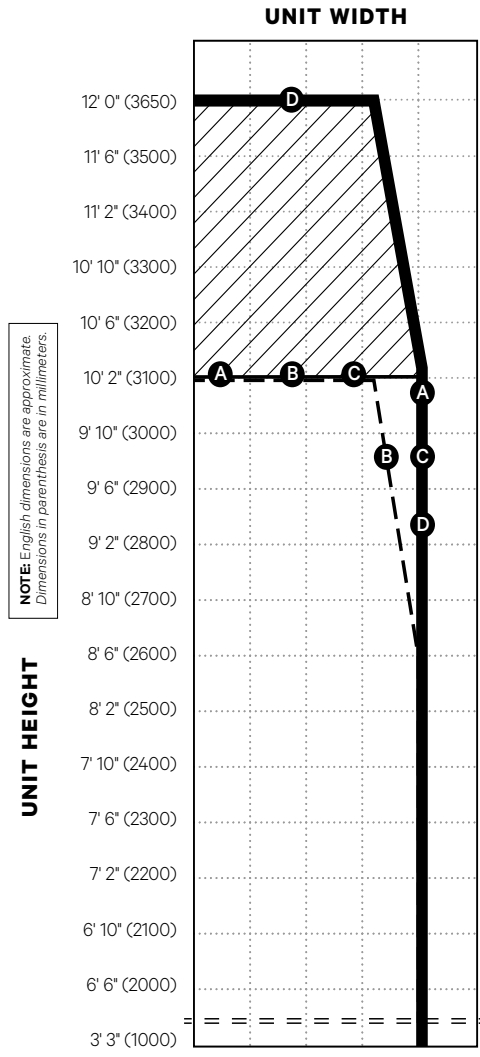

NOTE: English dimensions are approximate. Dimensions in parenthesis are in millimeters.

Number of Panels in Unit	Frame Width of Unit				
	1' 11" (600)	2' 3" (700)	2' 7" (800)	2' 11" (900)	3' 3" (1000)
1	3' 11" (1200)	4' 7" (1400)	5' 3" (1600)	5' 10" (1800)	6' 6" (2000)
2	5' 10" (1800)	6' 10" (2100)	7' 10" (2400)	8' 10" (2700)	9' 10" (3000)
3	7' 10" (2400)	9' 2" (2800)	10' 6" (3200)	11' 9" (3600)	13' 1" (4000)
4	9' 10" (3000)	11' 5" (3500)	13' 1" (4000)	14' 9" (4500)	16' 4" (5000)
5	11' 9" (3600)	13' 10" (4200)	15' 8" (4800)	17' 8" (5400)	19' 8" (6000)
6	13' 10" (4200)	16' 0" (4900)	18' 4" (5600)	20' 7" (6300)	22' 10" (7000)
7	15' 8" (4800)	18' 4" (5600)	20' 11" (6400)	23' 6" (7200)	26' 1" (8000)
8	17' 9" (5400)	20' 7" (6300)	23' 6" (7200)	26' 5" (8100)	29' 4" (9000)
9	19' 8" (6000)	22' 10" (7000)	26' 1" (8000)	29' 4" (9000)	32' 9" (10000)
10	21' 7" (6600)	25' 1" (7700)	28' 8" (8800)	32' 5" (9900)	36' 1" (11000)
11	23' 6" (7200)	27' 4" (8400)	31' 5" (9600)	35' 5" (10800)	39' 4" (12000)
12					

Any Custom Size is Possible Up to the Maximum Size Limit Lines Shown

**FOR UNIT STC 32 - 36 (max. 4.1 lbs/ft² [20 kg/m²])
MAXIMUM SIZE LIMIT LINE OF:**

A CONFIGURATIONS ———
(Swing panel at jamb only.)

Standard Configurations:

1L	1L 1R	1L 4R	2L 1R	4L 1R	6L 1R
1R	1L 2R	1L 6R			

B CONFIGURATIONS - - - -
(Swing panel as part of odd number of panels.)

Standard Configurations:

3L	5L	1L 3R	3L 2R	5L 1R	4L 3R	5L 3R	5L 4R	5L 6R
3R	5R	3L 1R	3L 3R	2L 5R	5L 2R	3L 6R	6L 3R	6L 5R
		2L 3R	1L 5R	3L 4R	3L 5R	4L 5R	5L 5R	

C CONFIGURATIONS ———
(No swing panels.)

Standard Configurations:

6L	2L 6R	4L 6R	6L 2R
6R			6L 4R
			6L 6R

D CONFIGURATIONS ———
(No swing panels.)

Standard Configurations:

2L	4L	2L 2R	4L 2R
2R	4R	2L 4R	4L 4R

Horizontal mullion required for unit height taller than 10' 2" (3100 mm) such that no glass pane is more than 7' 10" (2400 mm).

GLAZING

- Different glass thicknesses from 1/4" (6 mm) to 1 1/4" (32 mm).
- Dry glazing system.

NOTES

- Max. panel width swing panel attached to side jamb 3' 3" (1000 mm).
- Min. panel width 2' 3" (700 mm) for C Configuration.
- For special sizes and configurations, contact NanaWall.
- Higher sized panels (over 10' 2" [3100 mm] in height) may need to be operated by more than one person.

Interior Size Chart SL70: UNIT STC 38 to STC 42

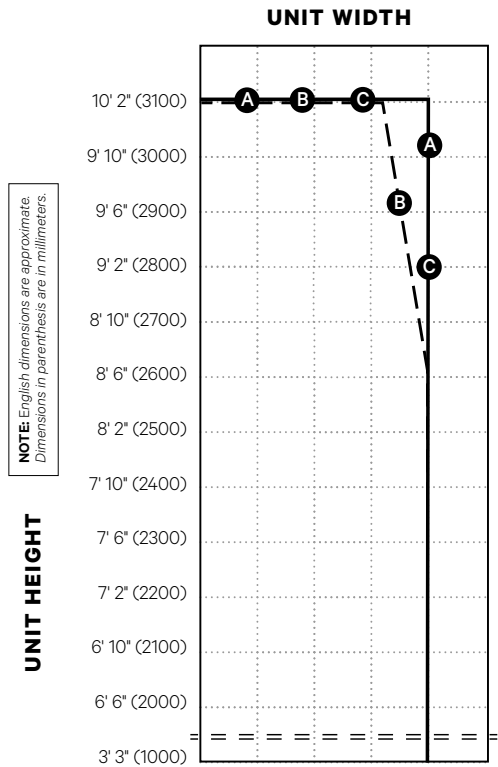

Number of Panels in Unit	1	1' 11" (600)	2' 3" (700)	2' 7" (800)	2' 11" (900)	3' 3" (1000)
	2	3' 11" (1200)	4' 7" (1400)	5' 3" (1600)	5' 10" (1800)	6' 6" (2000)
	3	5' 10" (1800)	6' 10" (2100)	7' 10" (2400)	8' 10" (2700)	9' 10" (3000)
	4	7' 10" (2400)	9' 2" (2800)	10' 6" (3200)	11' 9" (3600)	13' 1" (4000)
	5	9' 10" (3000)	11' 5" (3500)	13' 1" (4000)	14' 9" (4500)	16' 4" (5000)
	6	11' 9" (3600)	13' 10" (4200)	15' 8" (4800)	17' 8" (5400)	19' 8" (6000)
	7	13' 10" (4200)	16' 0" (4900)	18' 4" (5600)	20' 7" (6300)	22' 10" (7000)
	8	15' 8" (4800)	18' 4" (5600)	20' 11" (6400)	23' 6" (7200)	26' 1" (8000)
	9	17' 9" (5400)	20' 7" (6300)	23' 6" (7200)	26' 5" (8100)	29' 4" (9000)
	10	19' 8" (6000)	22' 10" (7000)	26' 1" (8000)	29' 4" (9000)	32' 9" (10000)
	11	21' 7" (6600)	25' 1" (7700)	28' 8" (8800)	32' 5" (9900)	36' 1" (11000)
	12	23' 6" (7200)	27' 4" (8400)	31' 5" (9600)	35' 5" (10800)	39' 4" (12000)

Frame Width of Unit

Any Custom Size is Possible Up to the Maximum Size Limit Lines Shown

FOR UNIT STC 38 - 42 (max. 6 lbs/ft² [30 kg/m²]) MAXIMUM SIZE LIMIT LINE OF:

A CONFIGURATIONS (Swing panel at jamb only.)

Standard Configurations:

1L	1L 1R	1L 4R	2L 1R	4L 1R	6L 1R
1R	1L 2R	1L 6R			

B CONFIGURATIONS (Swing panel as part of odd number of panels.)

Standard Configurations:

3L	5L	1L 3R	3L 2R	5L 1R	4L 3R	5L 3R	5L 4R	5L 6R
3R	5R	3L 1R	3L 3R	2L 5R	5L 2R	3L 6R	6L 3R	6L 5R
		2L 3R	1L 5R	3L 4R	3L 5R	4L 5R	5L 5R	

C CONFIGURATIONS (No swing panels.)

Standard Configurations:

2L	4L	6L	2L 2R	4L 2R	6L 2R
2R	4R	6R	2L 4R	4L 4R	6L 4R
			2L 6R	4L 6R	6L 6R

GLAZING

- Different glass thicknesses from 1/4" (6 mm) to 1 1/4" (32 mm).
- Dry glazing system.

NOTES

- Max. panel width swing panel attached to side jamb 3' 3" (1000 mm).
- Min. panel width 2' 3" (700 mm) for C Configuration.
- For special sizes and configurations, contact NanaWall.

Dimensions in millimeters unless noted. Calculation applies to the standard stiles and rails.

Glass dimensions of all panels in a unit are equal.

Nominal Panel Height (PH) is defined as Glass Daylight Opening Height + 117 = Glass Daylight Opening Height + 4 5/8".

Nominal Panel Width (PW) is defined as Glass Daylight Opening Width + 117 = Glass Daylight Opening Width + 4 5/8".

Panel Height is as seen from the inside on an inward opening unit and is as seen from the outside on an outward opening unit. Please note that with the overlap of the head jamb and the sill with the panel, the Clear Opening Height will not be the same as the Panel Height.

See Cross-Section Details of both stiles of each panel to determine actual Panel Width. With astragals, overlapping, etc., the actual Panel Width not only varies with position of panel in a configuration, but the inside and outside surface widths of each stile may be different. Running posts and astragals are not included in Panel Width dimensions.

For each configuration, the Frame Width (FW) is the sum of the nominal Panel Width (PW) x the number of panels + a number (N) which is the sum of the side jamb dimensions and dimensions of space between panels in excess of the nominal Panel Width as shown in the Cross-Section Details.

Frame Height (FH) SL70 System

Higher Weather Performance (Raised) Sill: Frame Height = Panel Height + 84 (3 5/16") = Clear Opening Height + 130 (5 1/8")

Flush Sill: Frame Height = Panel Height + 99 (3 7/8") = Clear Opening Height + 115 (4 1/2")

Low Profile Saddle Sill: Frame Height = Panel Height + 99 (3 7/8") = Clear Opening Height + 115 (4 1/2")

Surface Mounted Interior Sill: Frame Height = Panel Height + 72 (2 13/16") = Clear Opening Height + 88 (3 7/16")

Frame Widths for Different Configurations with Majority of Panels Folding to Right (and their Mirror Image Configurations with Majority of Panels Folding to Left). See Maximum Size Charts for size limits. These numbers can be used as a guideline only. Contact NanaWall for the exact calculations for a particular unit.

Please note that widths for units with angle turns will be different.

Model 1R	Frame Width = 1 x Panel Width + 139 = 1 x Panel Width + 5 1/2"
Model 1L1R	Frame Width = 2 x Panel Width + 172 = 2 x Panel Width + 6 3/4"
Model 2R	Frame Width = 2 x Panel Width + 190 = 2 x Panel Width + 7 1/2"
Model 3R	Frame Width = 3 x Panel Width + 219 = 3 x Panel Width + 8 5/8"
Model 1L2R	Frame Width = 3 x Panel Width + 222 = 3 x Panel Width + 8 3/4"
Model 4R	Frame Width = 4 x Panel Width + 270 = 4 x Panel Width + 10 5/8"
Model 1L3R	Frame Width = 4 x Panel Width + 252 = 4 x Panel Width + 9 15/16"
Model 2L2R	Frame Width = 4 x Panel Width + 300 = 4 x Panel Width + 11 13/16"
Model 5R	Frame Width = 5 x Panel Width + 299 = 5 x Panel Width + 11 13/16"
Model 1L4R, Model 2L3R	Frame Width = 5 x Panel Width + 302 = 5 x Panel Width + 11 15/16"
Model 3L3R, Model 1L5R	Frame Width = 6 x Panel Width + 332 = 6 x Panel Width + 13 1/16"
Model 2L4R	Frame Width = 6 x Panel Width + 380 = 6 x Panel Width + 14 15/16"
Model 6R	Frame Width = 6 x Panel Width + 350 = 6 x Panel Width + 13 3/4"
Model 3L4R, Model 2L5R, Model 1L6R	Frame Width = 7 x Panel Width + 382 = 7 x Panel Width + 15 1/16"
Model 4L4R, Model 2L6R	Frame Width = 8 x Panel Width + 460 = 8 x Panel Width + 18 1/8"
Model 3L5R	Frame Width = 8 x Panel Width + 412 = 8 x Panel Width + 16 1/4"
Model 4L5R, Model 3L6R	Frame Width = 9 x Panel Width + 462 = 9 x Panel Width + 18 3/16"
Model 5L5R	Frame Width = 10 x Panel Width + 492 = 10 x Panel Width + 19 3/8"
Model 4L6R	Frame Width = 10 x Panel Width + 540 = 10 x Panel Width + 21 1/4"
Model 5L6R	Frame Width = 11 x Panel Width + 542 = 11 x Panel Width + 21 3/8"
Model 6L6R	Frame Width = 12 x Panel Width + 620 = 12 x Panel Width + 24 7/16"

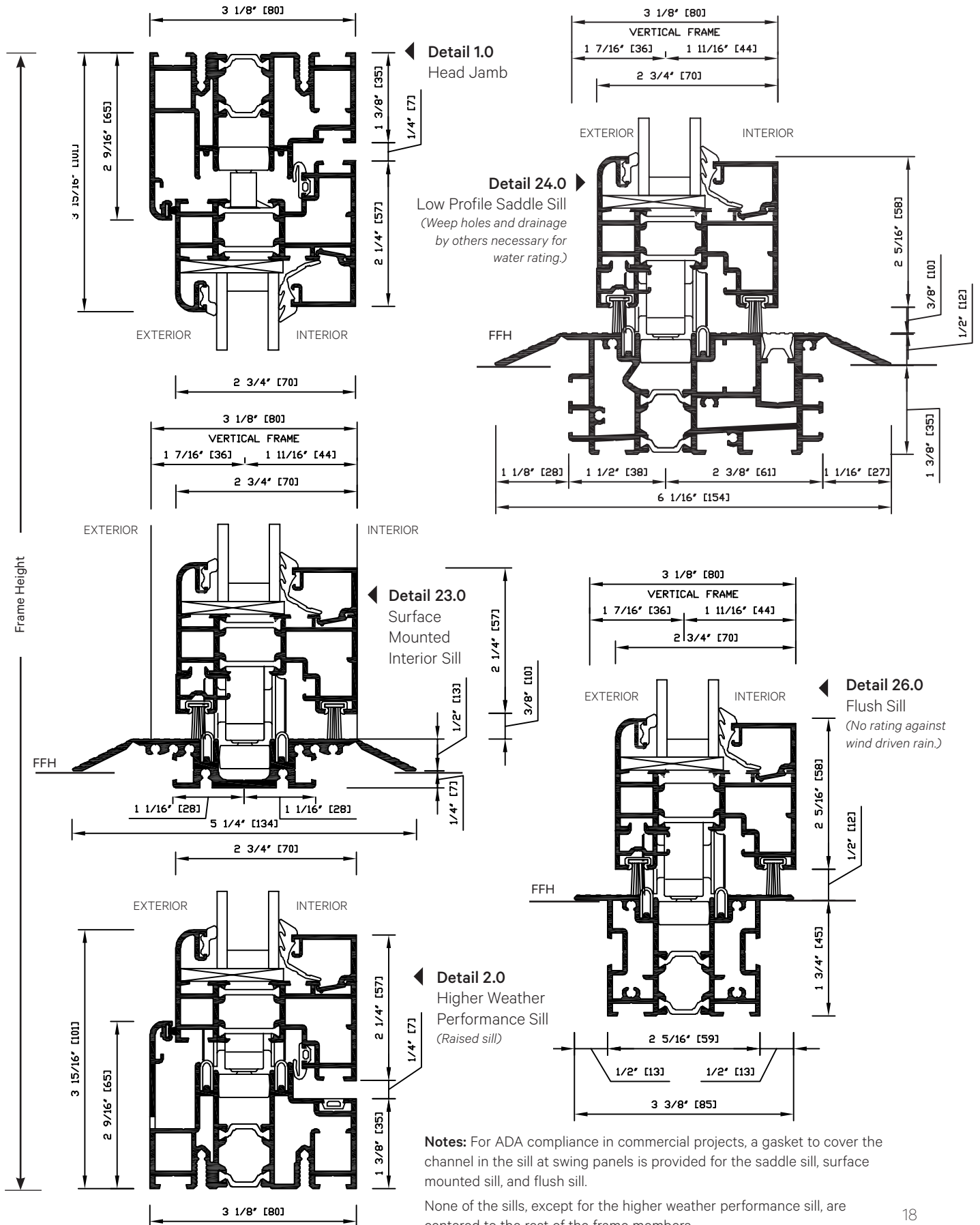

Notes: For ADA compliance in commercial projects, a gasket to cover the channel in the sill at swing panels is provided for the saddle sill, surface mounted sill, and flush sill.

None of the sills, except for the higher weather performance sill, are centered to the rest of the frame members.

Detail 4R.0 Swing panel with locking right side jamb

Detail 4.0 Swing panel with locking left side jamb

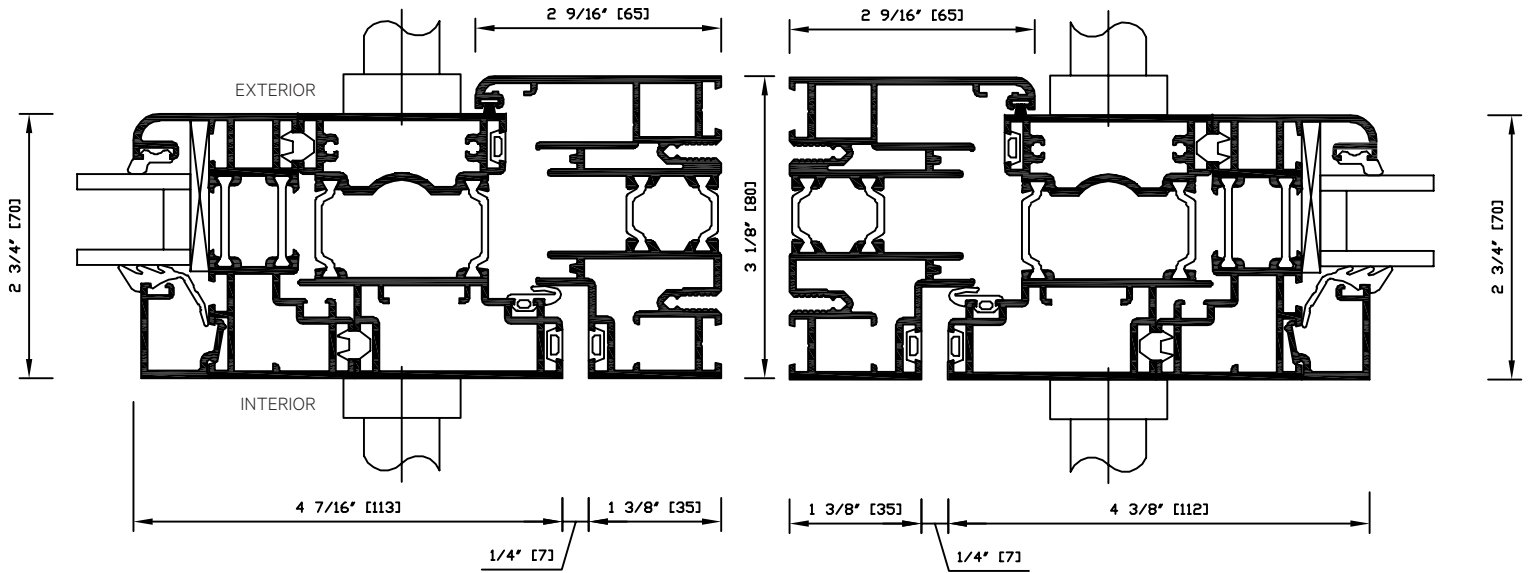

Detail 7.0 & 7R.0
Folding panels with locking

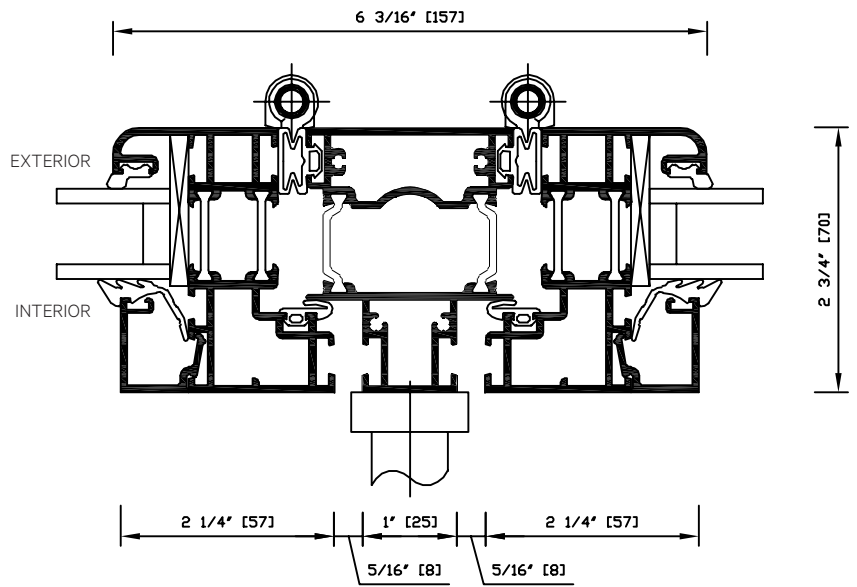

Detail 7C.0 & 7RC.0
Folding panels with running carriage set

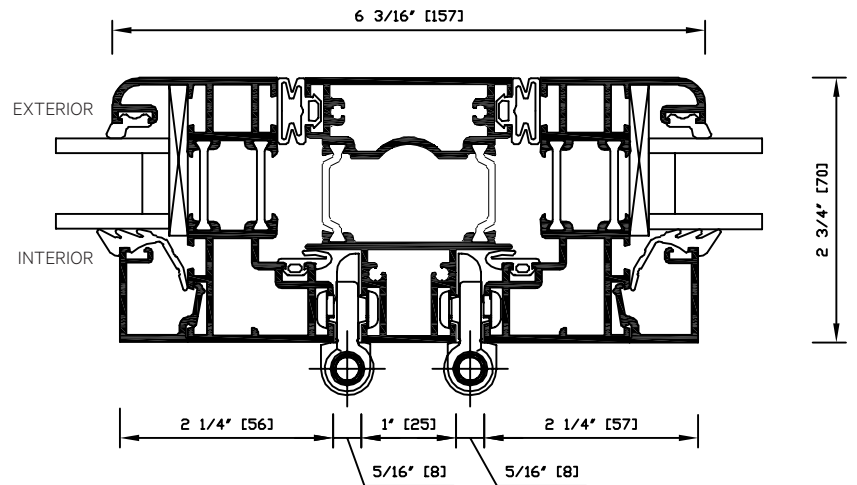

Detail 10.0

Meeting of swing panel with locking on left and folding panel with running carriage set on right

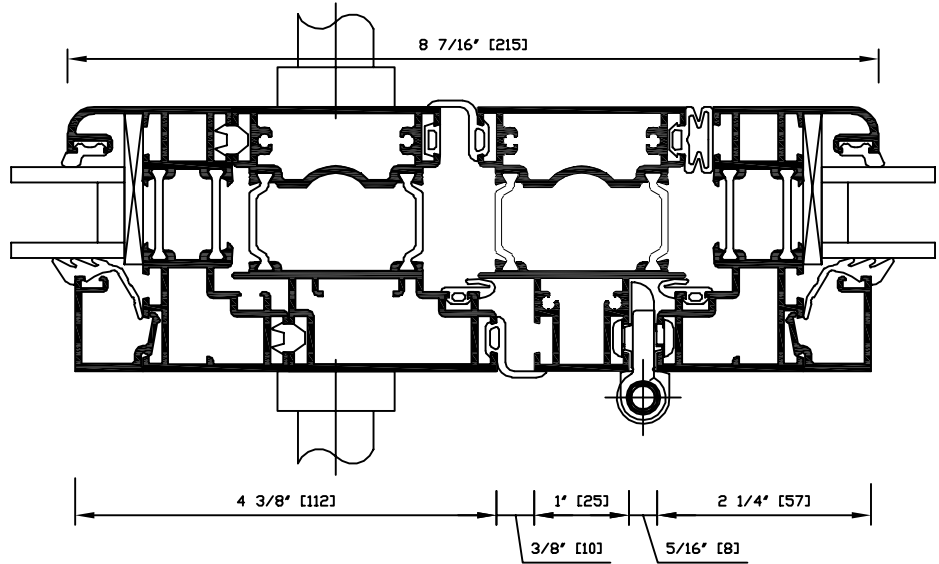

Detail 10R.0

Meeting of swing panel with locking on right and folding panel with running carriage set on left

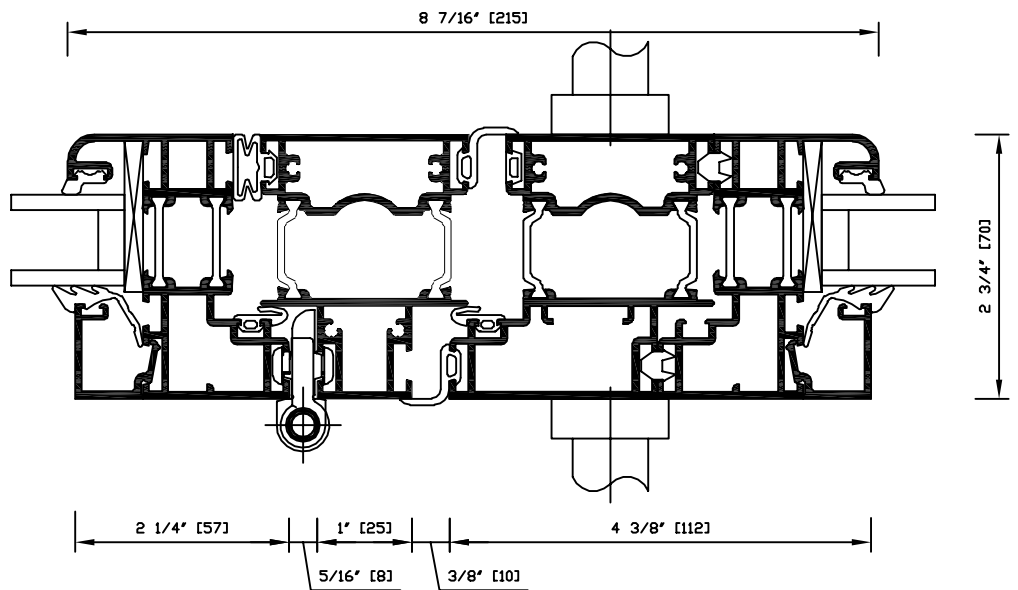

Detail 5.0

Panel with running carriage set meeting left side jamb

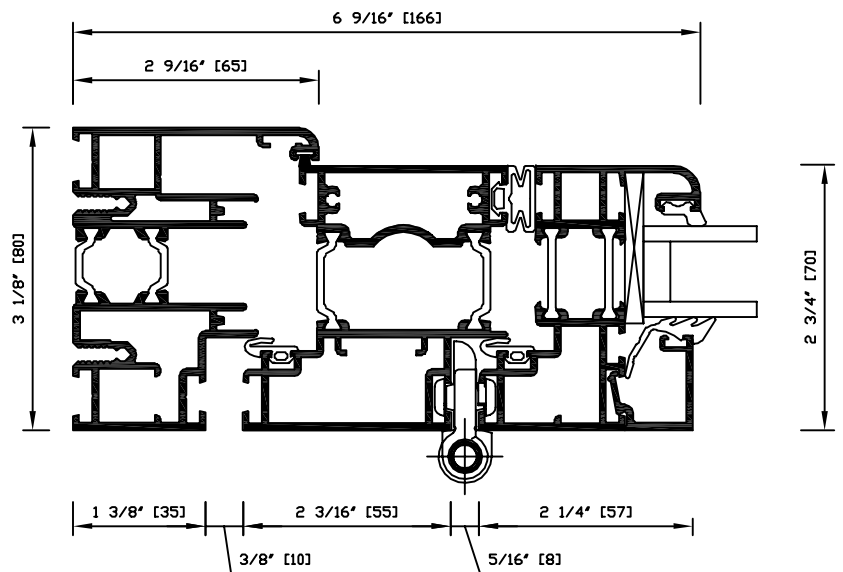

Detail 5R.0
Panel with running carriage set meeting right side jamb

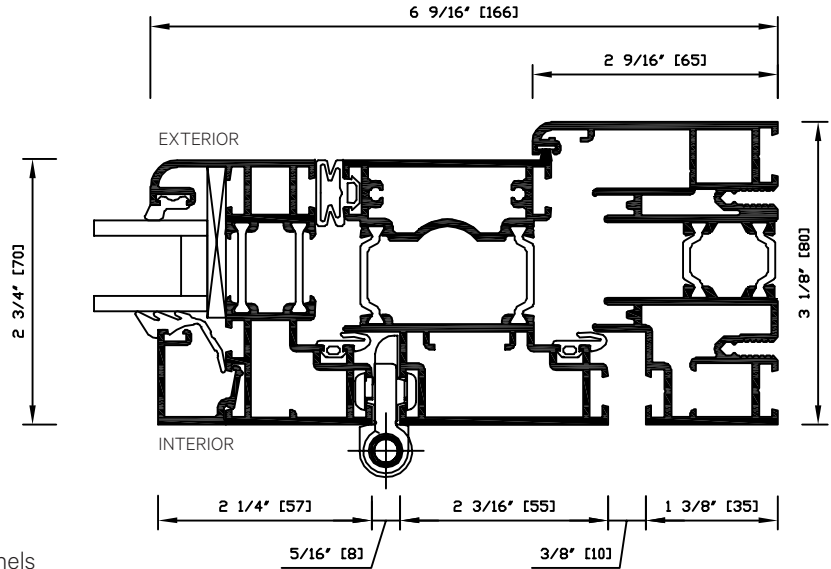

Detail 9R.0
Meeting of panels folding to opposite sides (no swing panel). Running carriage sets on both panels

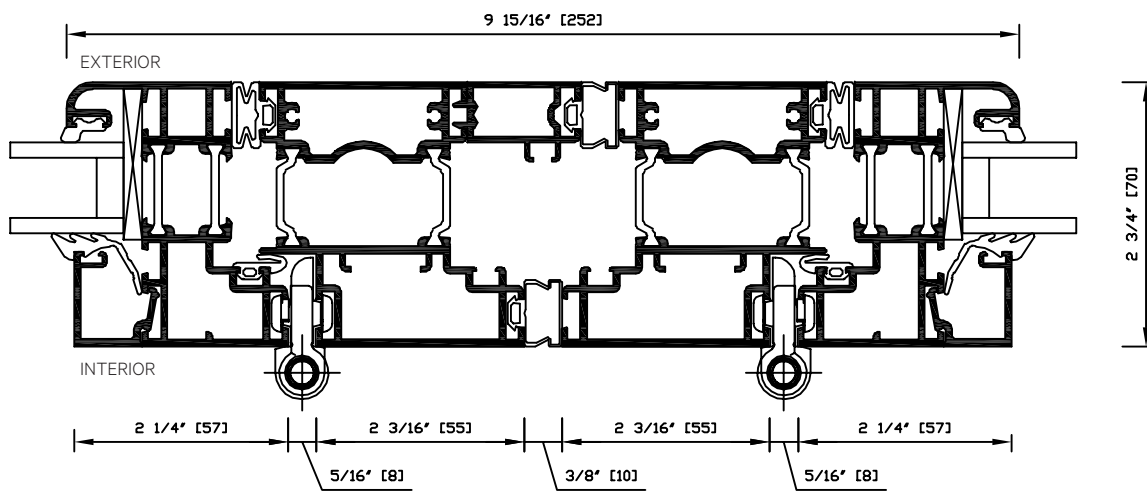

Detail 9.0
Meeting of panels folding to opposite sides (no swing panel). Running carriage sets on both panels

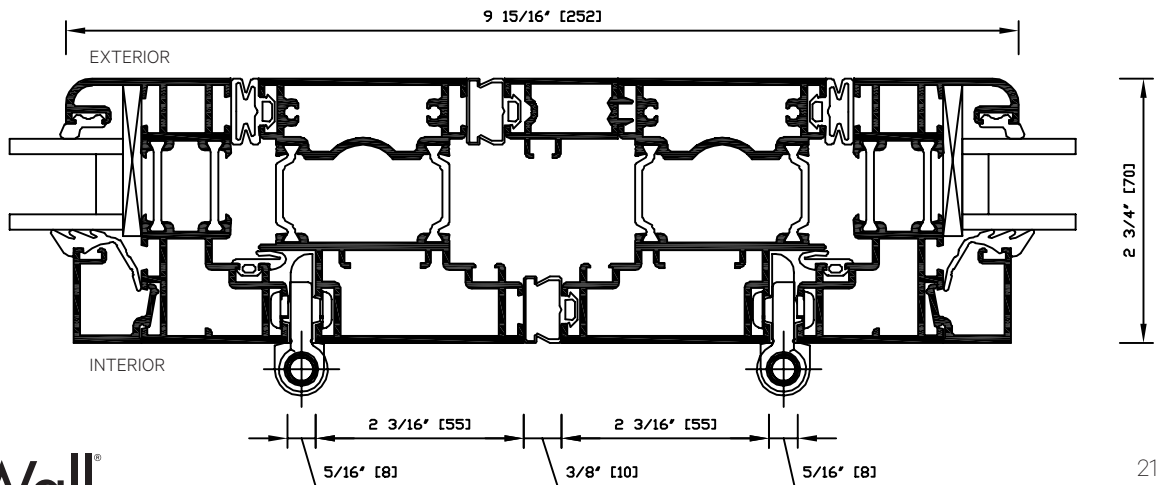

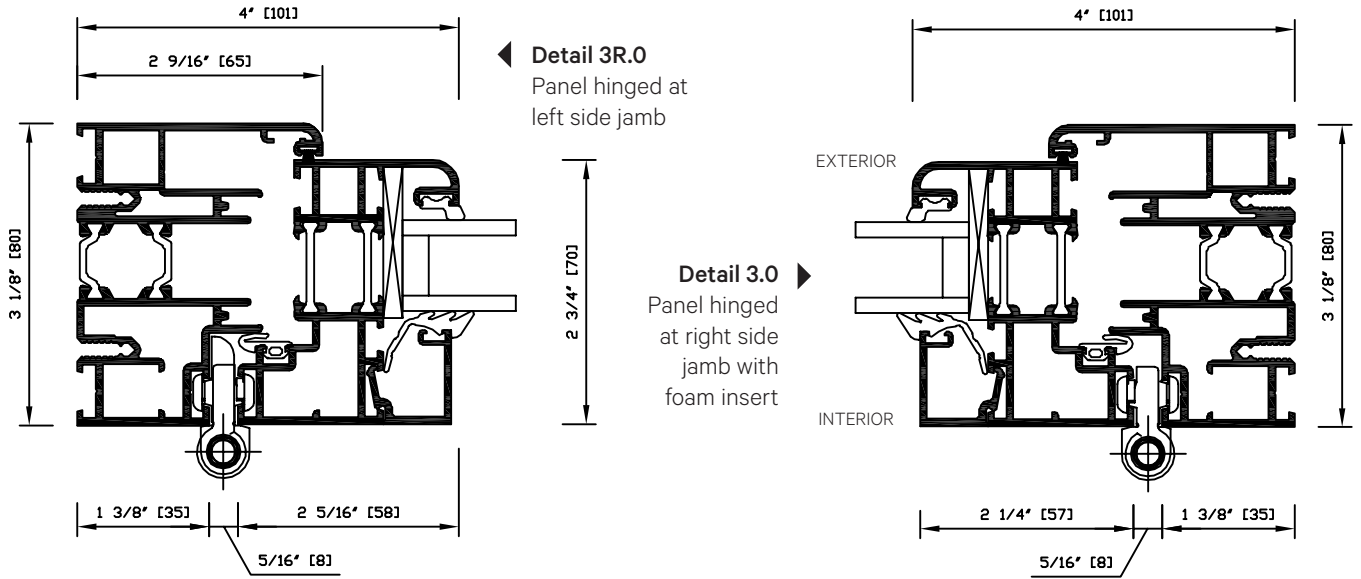

Inward Opening Section Details

Detail 8.0
Two swing panels with locking: left panel opening first

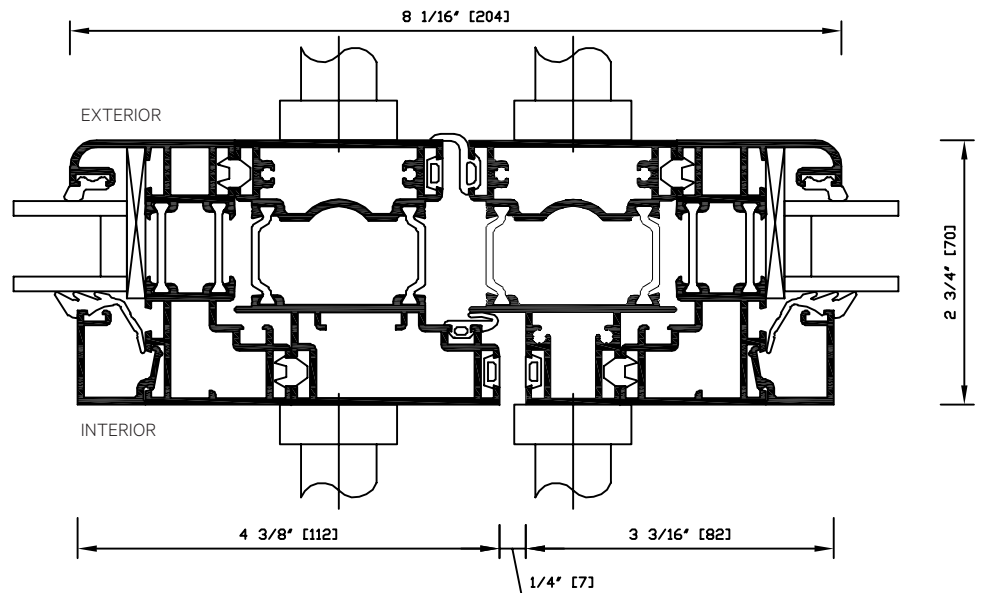

Detail 8R.0
Two swing panels with locking: right panel opening first

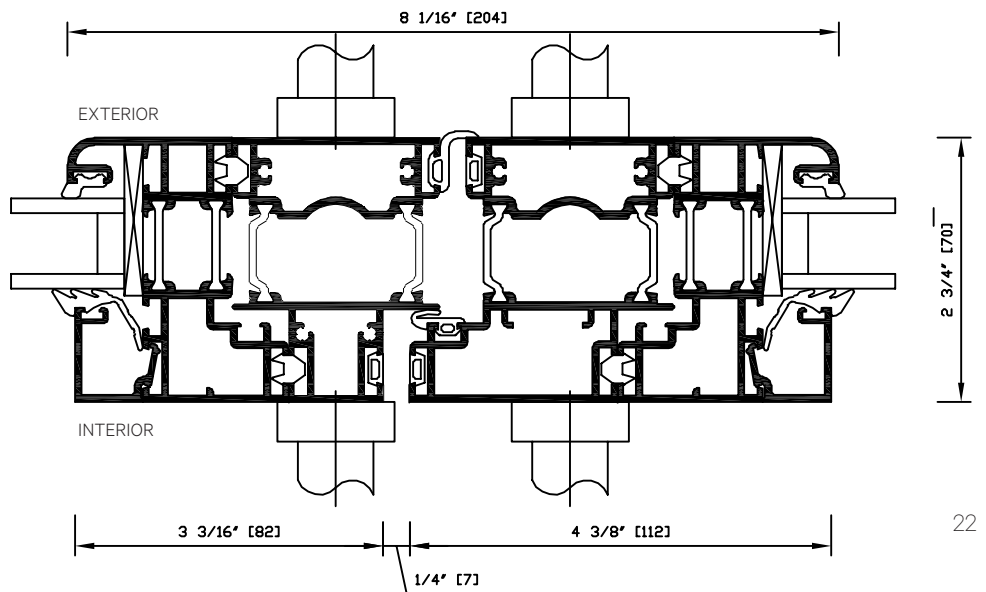

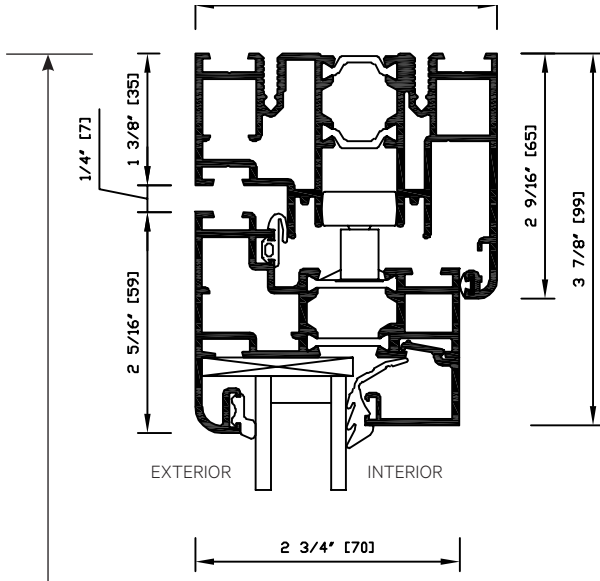

Detail 1.1
Head Jamb

Detail 24.1
Low Profile
Saddle Sill
(Weep holes
and drainage by
others necessary
for water rating.)

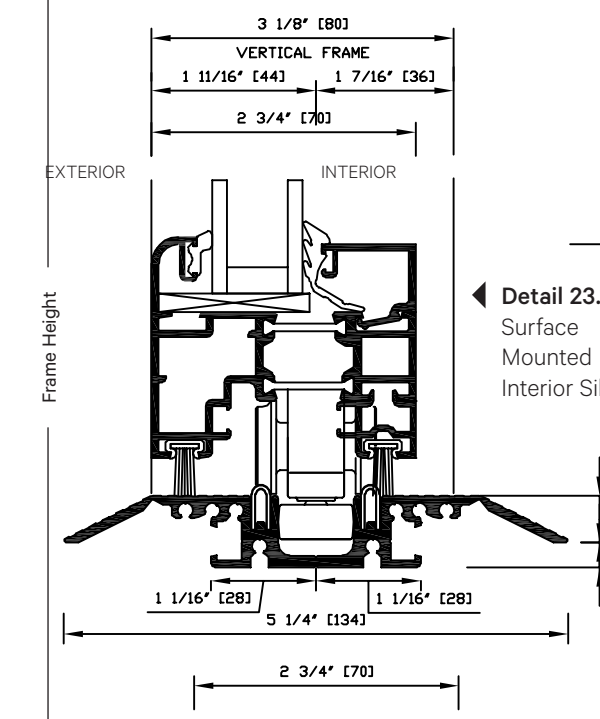
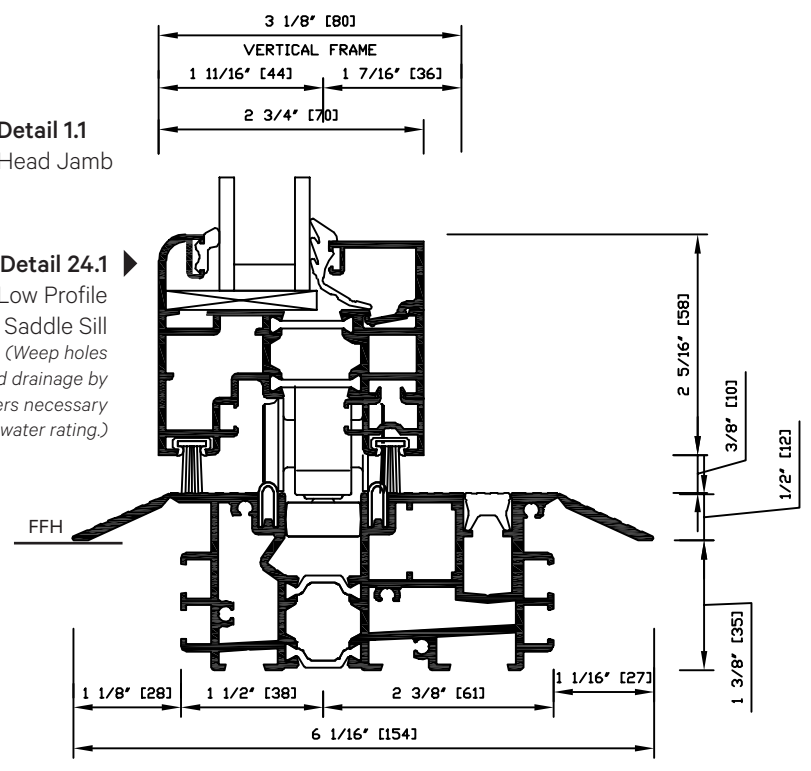

Detail 23.1
Surface
Mounted
Interior Sill

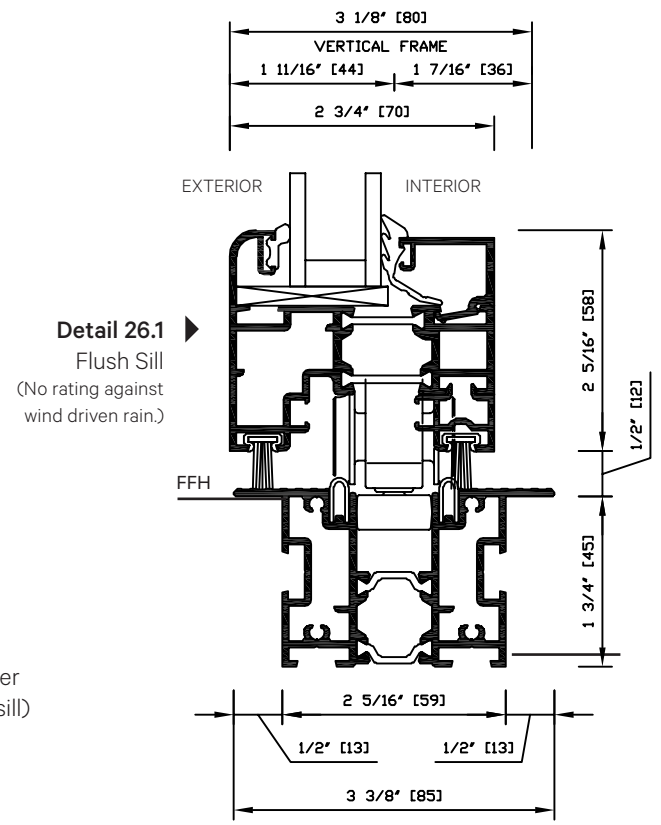

Detail 26.1
Flush Sill
(No rating against
wind driven rain.)

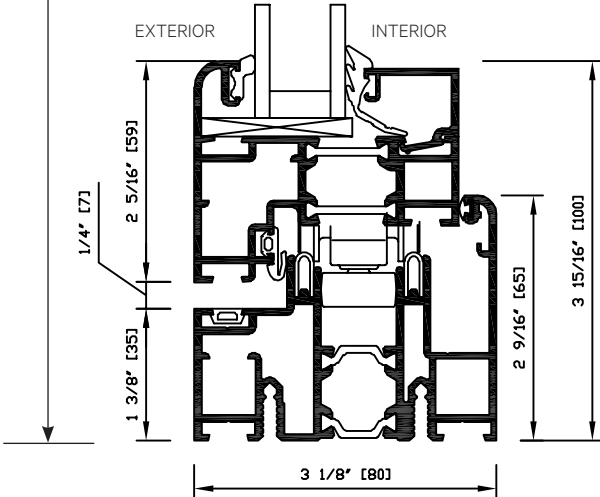

Detail 2.1
Raised Sill
(higher weather
performance sill)

Notes: For ADA compliance in commercial projects, a gasket to cover the channel in the sill at swing panels is provided for the saddle sill, surface mounted sill, and flush sill.

None of the sills, except for the higher weather performance sill, are centered to the rest of the frame members.

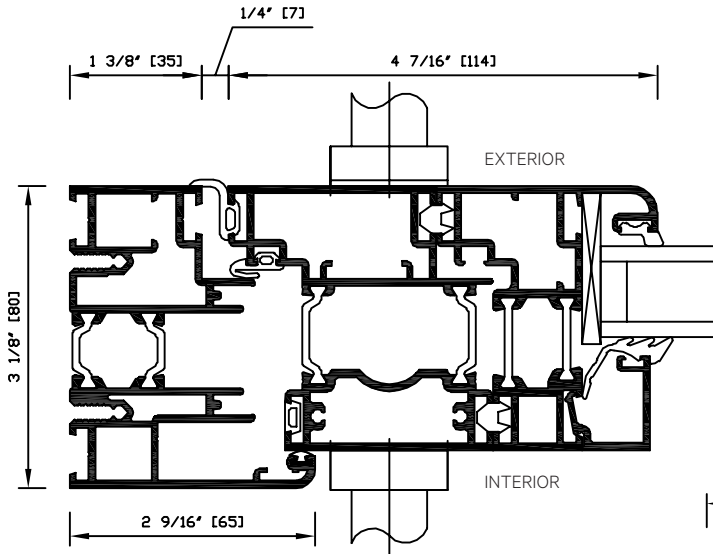

Detail 4.1
Swing panel with locking at left side jamb

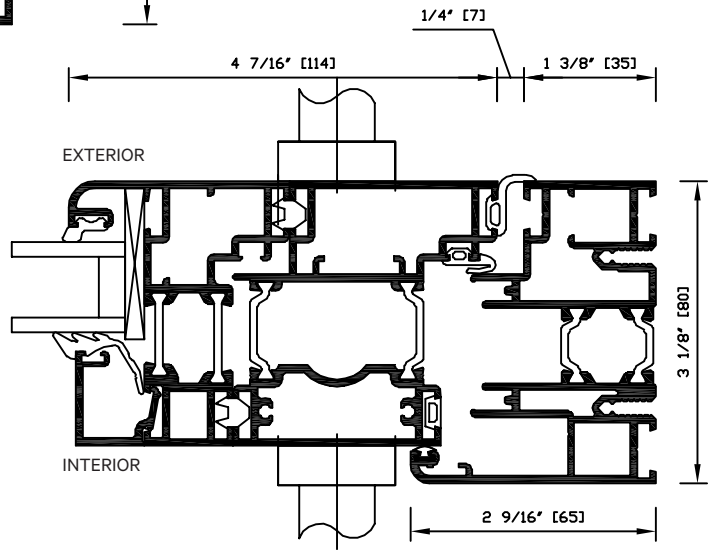

Detail 4R.1
Swing panel with locking at right side jamb

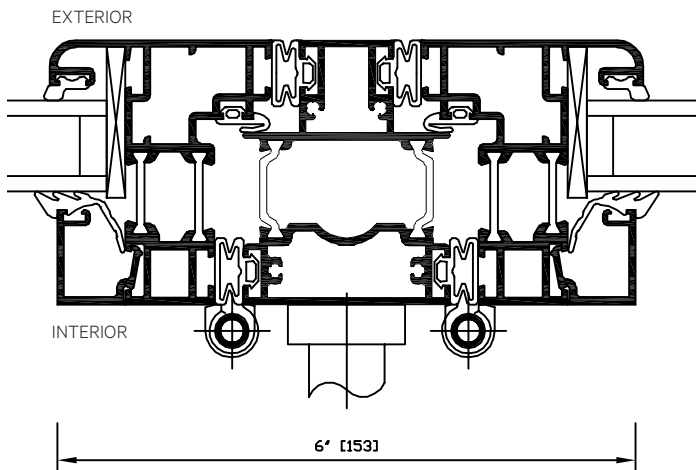
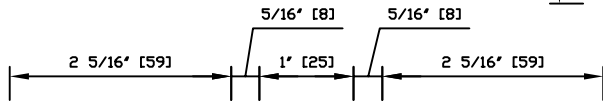

Detail 7.1 & 7R.1
Folding panels with locking

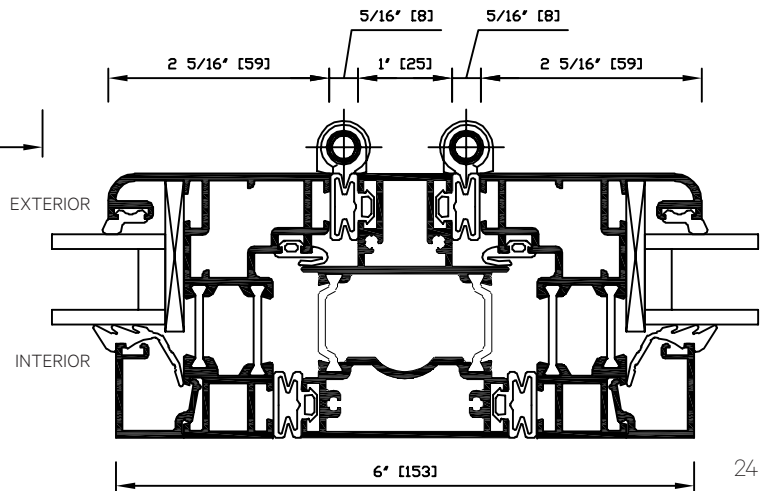

Detail 7C.1 and 7RC.1
Folding panels with running carriage set

Detail 10.1

Meeting of swing panel with inside locking on left and folding panel with running carriage set on right.

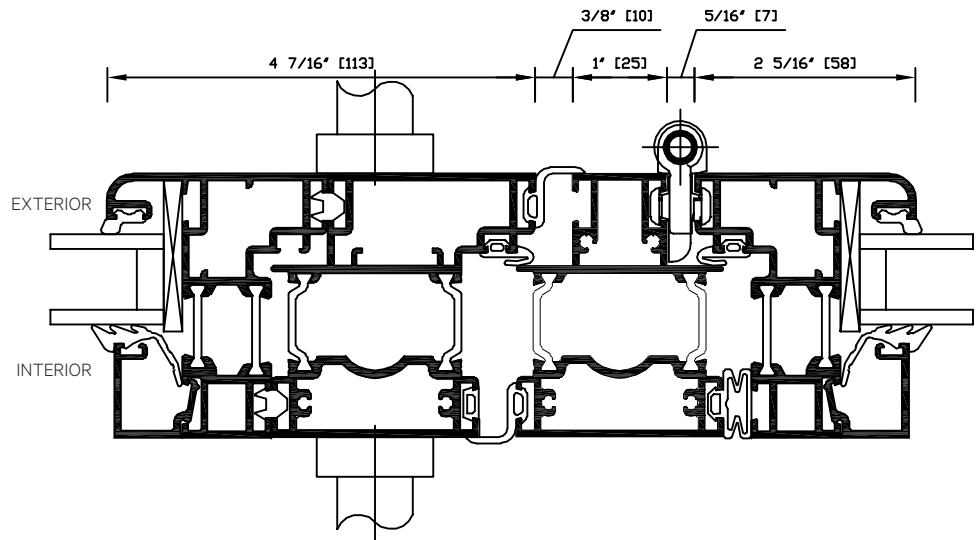

Detail 10R.1

Meeting of swing panel with inside locking on right and folding panel with running carriage set on left.

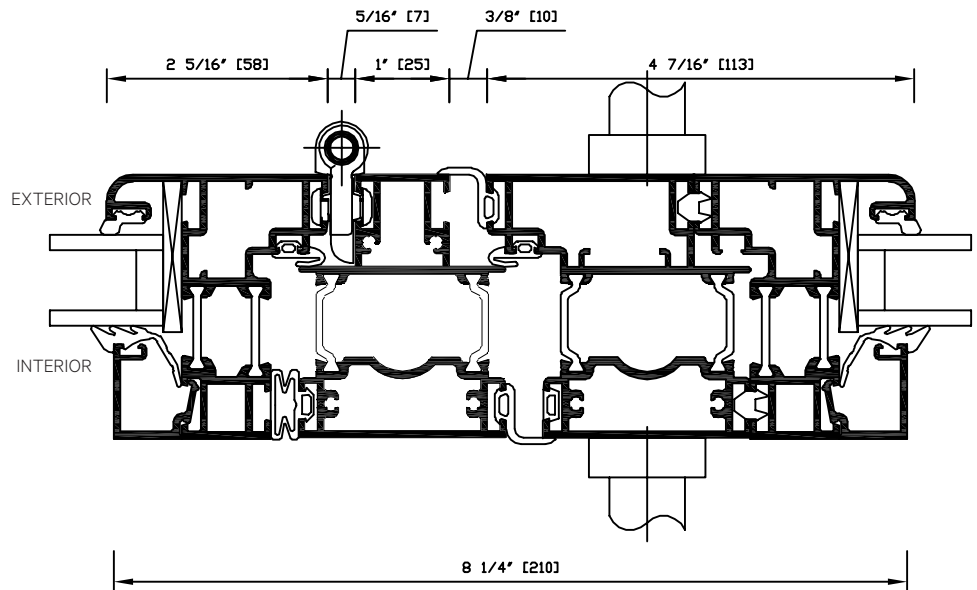

Detail 5.1

Panel with running carriage set meeting left side jamb

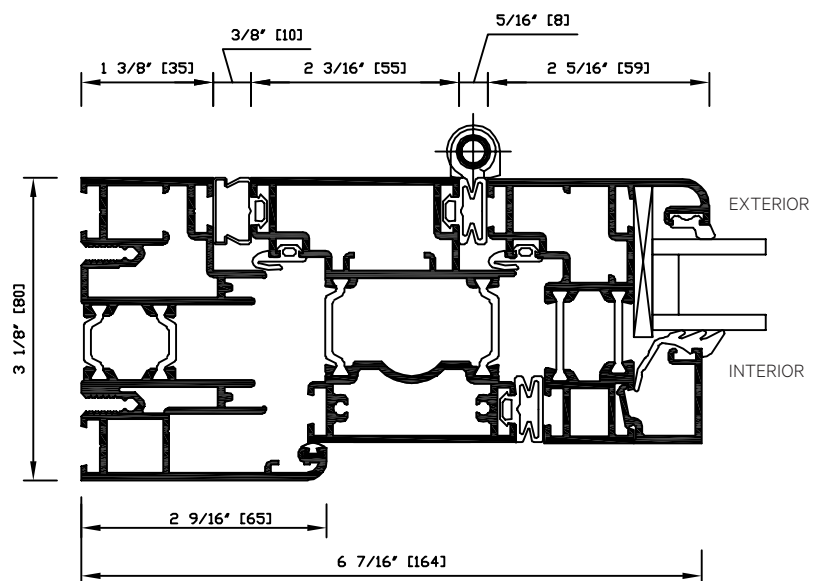

Detail 5R.1

Panel with running carriage set meeting right side jamb

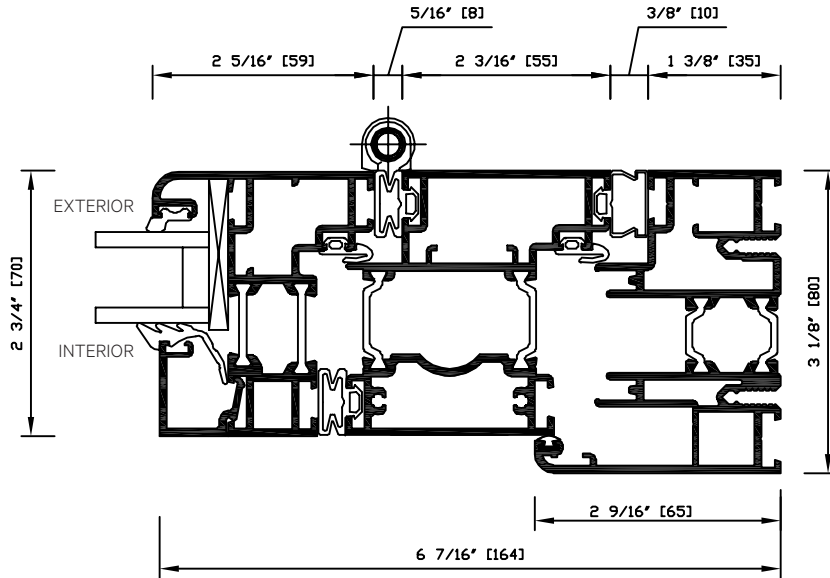

Detail 9R.1

Meeting of panels folding to opposite sides (no swing panel). Running carriage sets on both panels.

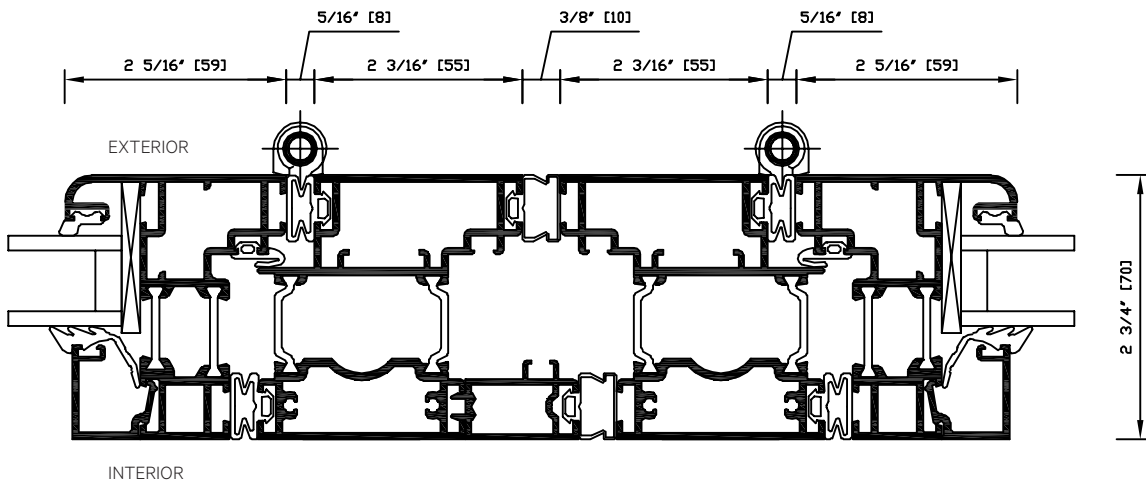
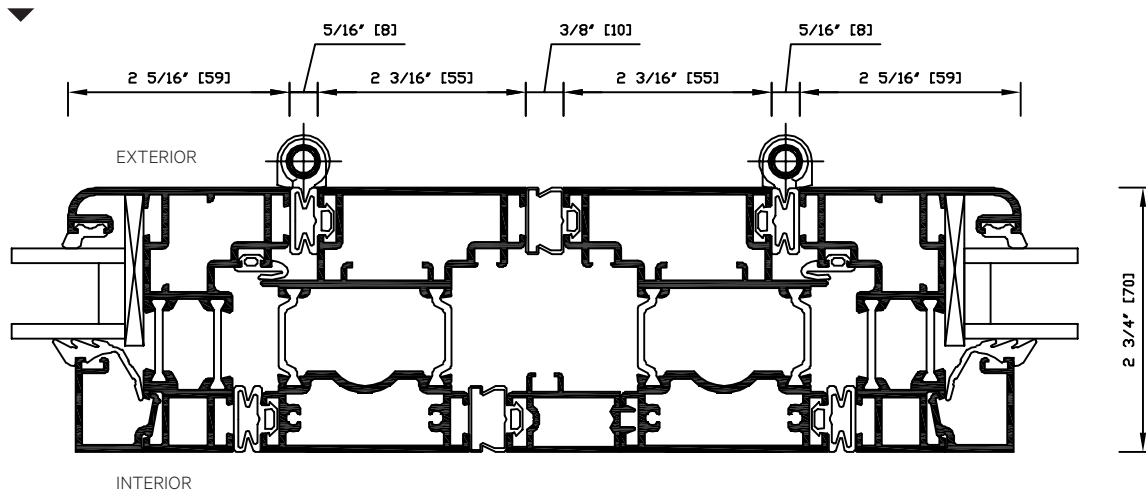

Detail 9.1
Meeting of panels folding to opposite sides (no swing panel). Running carriage sets on both panels.

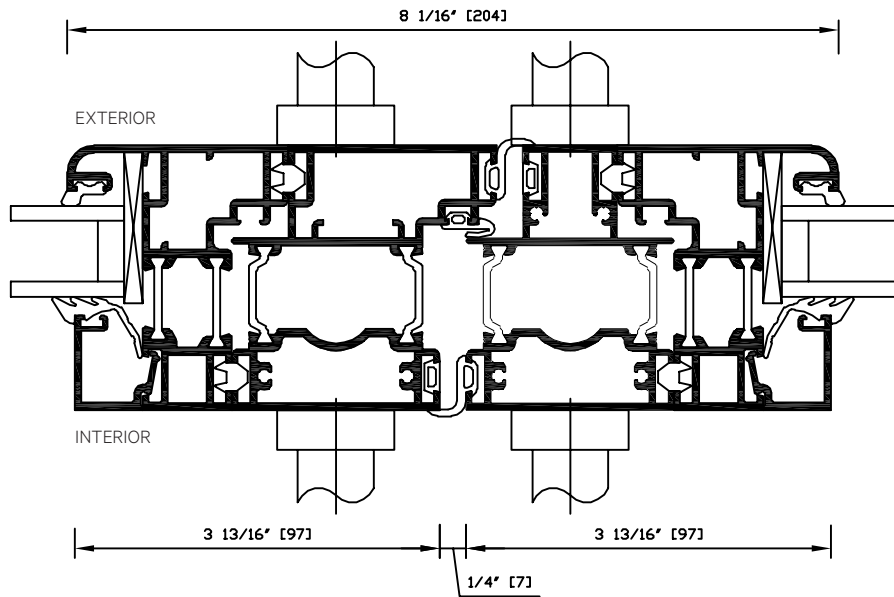
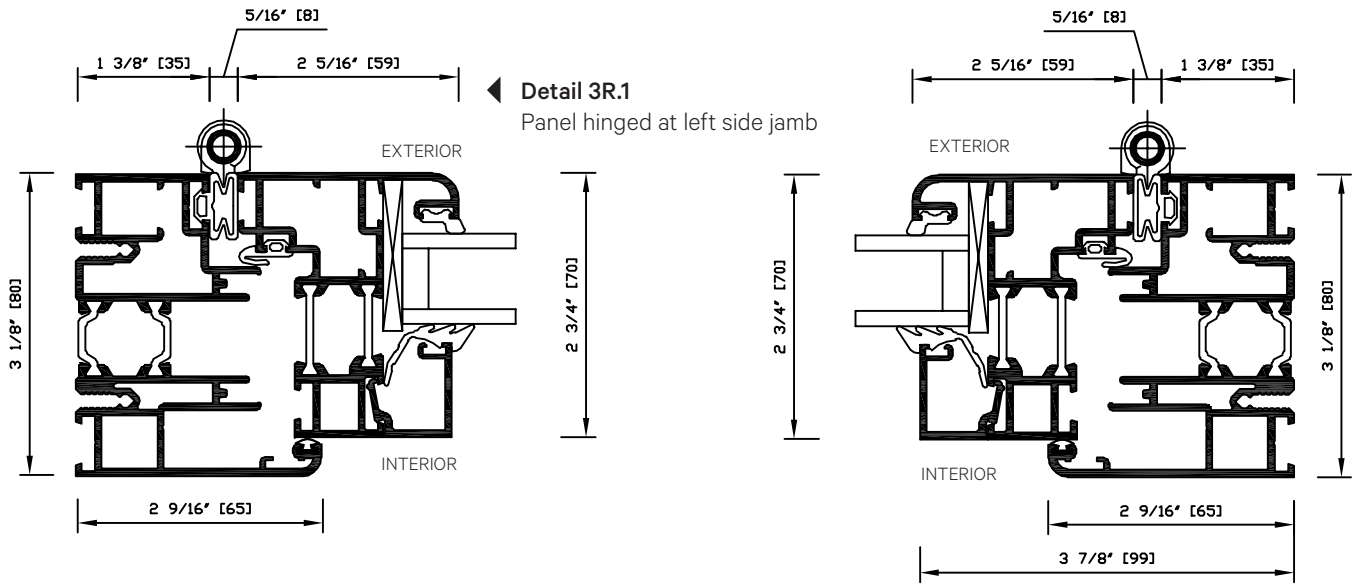

Detail 8R.1 ▶
Two swing panels with locking:
right panel opening first

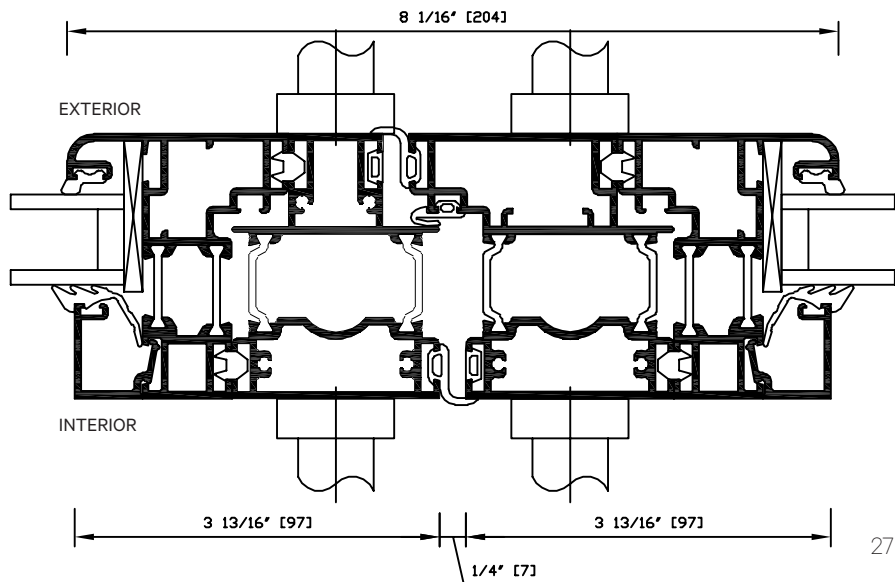

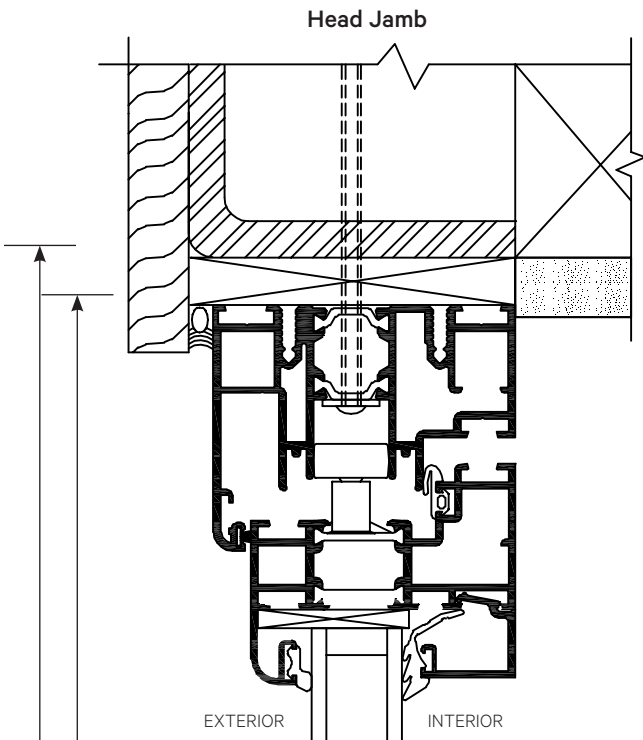

Rough Opening From Subfloor
Frame Height

Standard Higher Weather Performance Sill (Raised Sill)

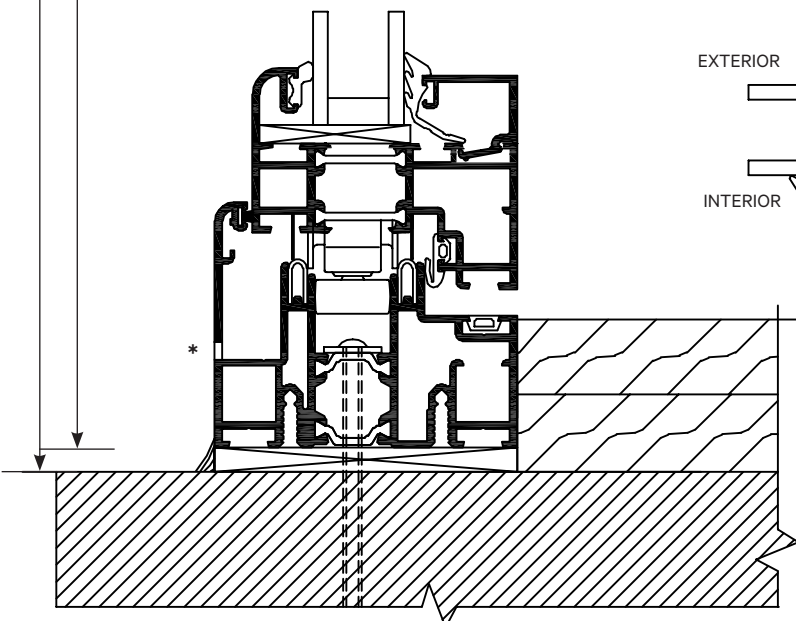

* Do not cover weep holes

INSTALLATION NOTES

Suggested Typical Installation drawings shown are very general and may not be suitable for any particular installation. Product placement, fasteners, flashing, waterproofing, sealant, trim, and other details for specific surrounding conditions must be properly designed and provided by others.

INSTALLATION CONSIDERATIONS

The approximate weight of a panel with double glazing is 5.5-7.5 lbs/ft² (27-37 kg/m²), and with triple glazing is 7-8 lbs/ft² (34-39 kg/m²). The vertical structural deflection of the header should be the lesser of L/720 of the span and ¼" (6 mm) under full loads. Although for Floor Supported systems, there is no vertical load on the header from the panels, structural support for lateral loads (both windload and when the panels are stacked open) must be provided. See "Pre-Installation Preparation and Installation Guidelines" in the General Introduction. An owner's manual with installation instructions is available upon request.

It is recommended that all building dead loads be applied to the header prior to installing the NanaWall. If so and if a reasonable amount of time has been allowed for the effect of this dead load on the header, then only the building's live load can be used to meet the above requirements of L/720 or ¼" (6 mm). If not, both the dead and live loads need to be considered. For the Floor Supported SL70, please note that there is no vertical load on the header.

Note: For some jurisdictions, any standing water in sill channels must be drained. Weep holes for this purpose are to be done by others in the field, including drain connections if sill is recessed.

Panel Hinged At Right Side Jamb

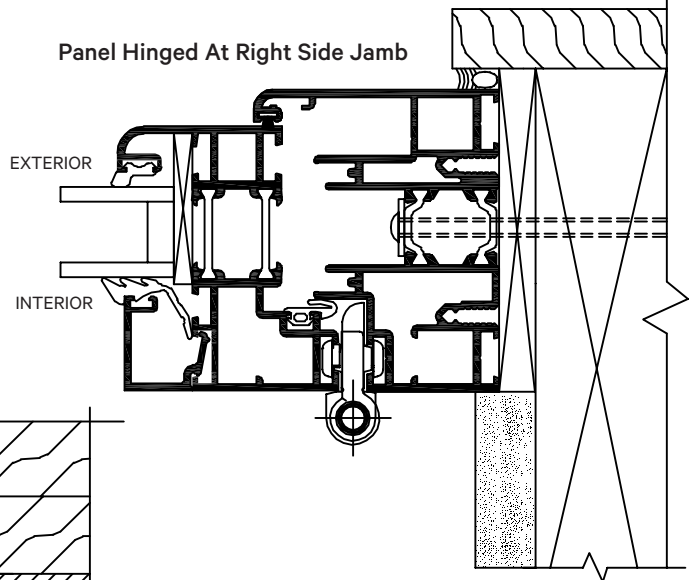

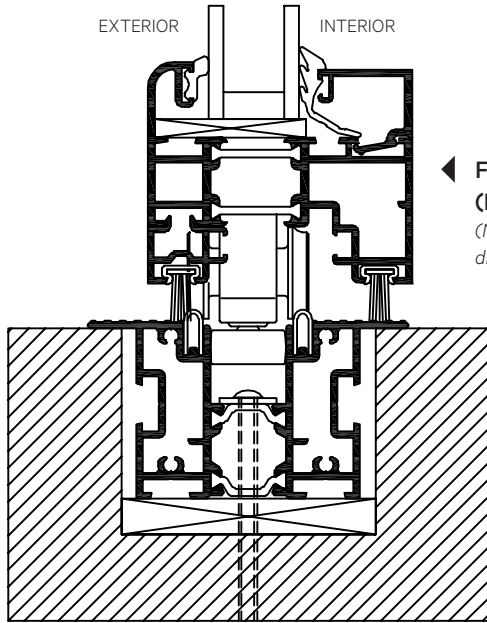

◀ **Flush Sill
(Inward Opening)**
(No rating against wind driven rain.)

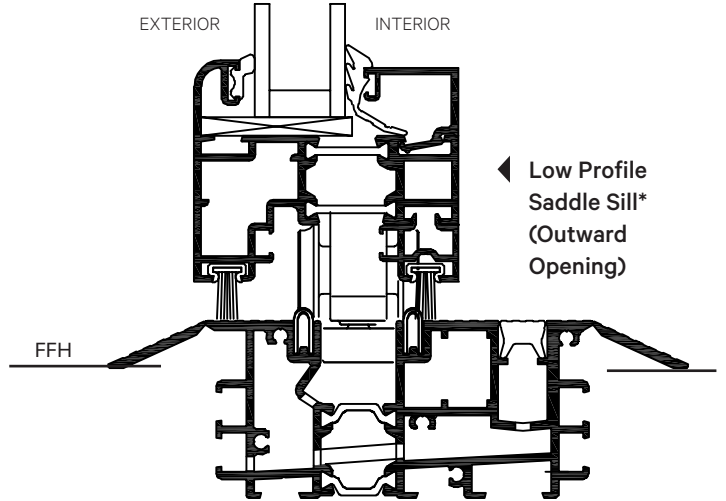

◀ **Low Profile Saddle Sill*
(Outward Opening)**

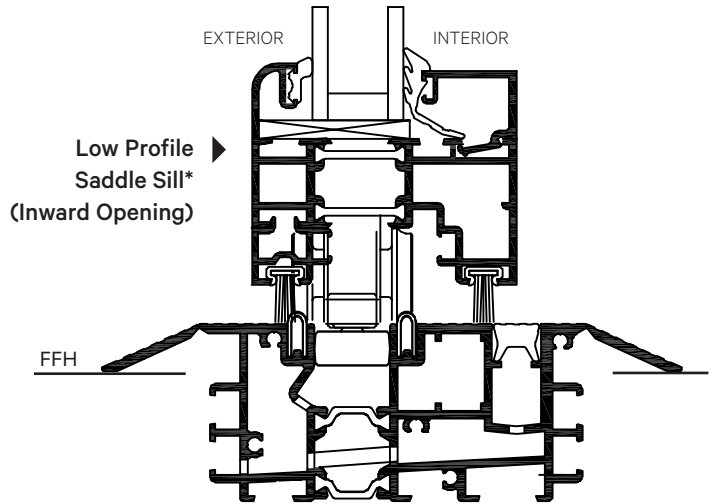

▶ **Low Profile Saddle Sill*
(Inward Opening)**

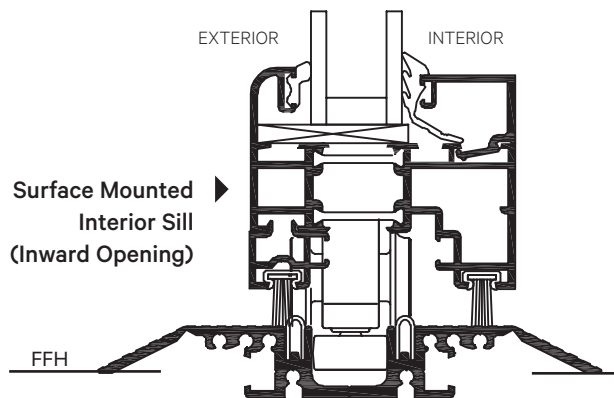

▶ **Surface Mounted Interior Sill
(Inward Opening)**

NOTES

Suggested Typical Installation drawings shown are very general and may not be suitable for any particular installation. Product placement, fasteners, flashing, waterproofing, sealant, trim, and other details for specific surrounding conditions must be properly designed and provided by others.

***Low Profile Saddle Sill for Inward or Outward Opening**

For resistance against wind driven rain, the following is recommended by others:

1. Remove the gasket covering the inner channel.
2. Provide necessary weepholes at the bottom of channels and on the outside face of the sill.
3. Make necessary drain connections.

Contact NanaWall for a detailed drawing.

See Installation Considerations on Page 28.

Note: None of the sills, except for the higher weather performance sill, are centered to the rest of the frame members.

Note: For ADA compliance in commercial projects, for swing panels, a gasket to cover the channel in the sill at swing panels is provided for the saddle sill, surface mounted sill, and flush sill.

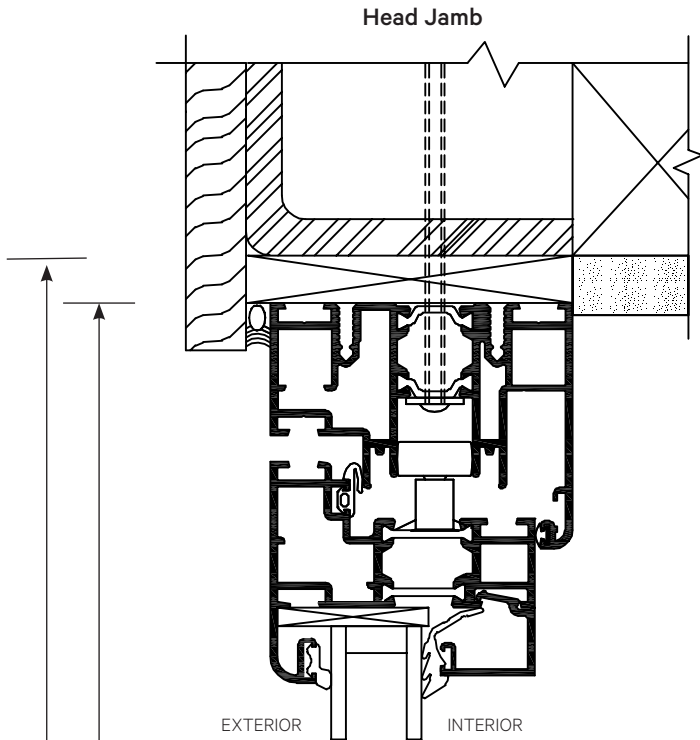

INSTALLATION NOTES

Suggested Typical Installation drawings shown are very general and may not be suitable for any particular installation. Product placement, fasteners, flashing, waterproofing, sealant, trim, and other details for specific surrounding conditions must be properly designed and provided by others.

For Installation Considerations, please see notes on page 28.

Rough Opening From Subfloor
Frame Height

Panel Hinged At Right Side Jamb

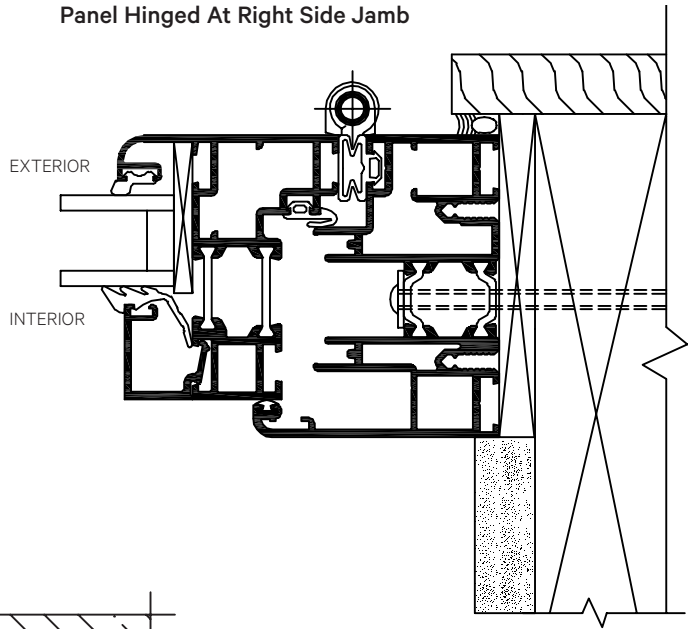

Higher Weather Performance Sill (Raised Sill) Installation

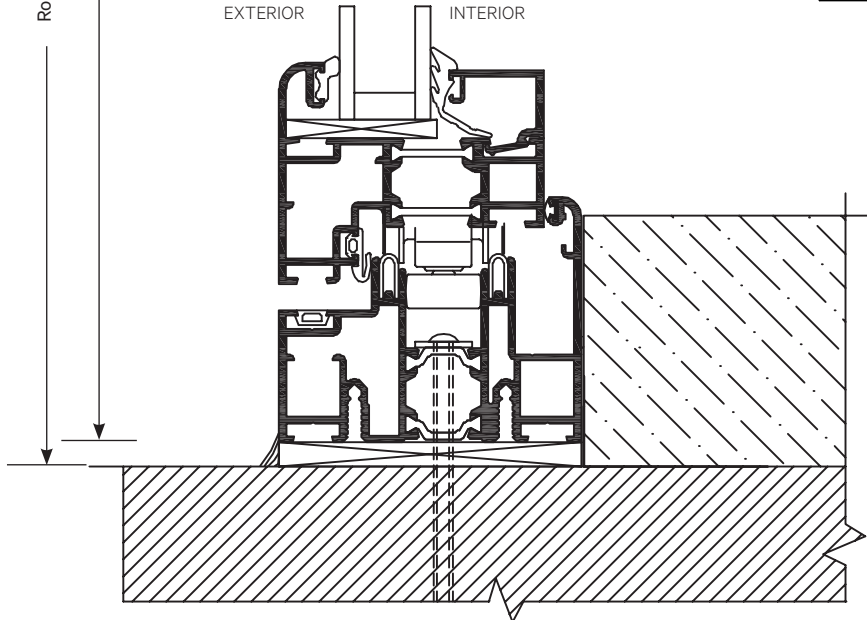

Typical Mullion Profile

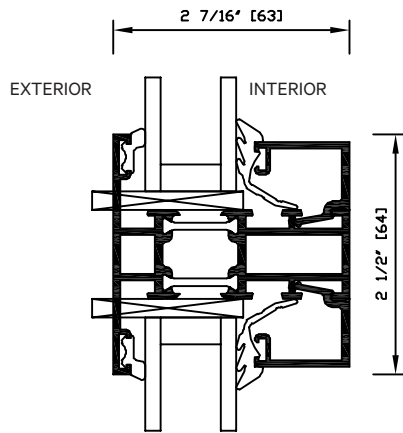

Typical Glass Stop Profile with Triple Glazing

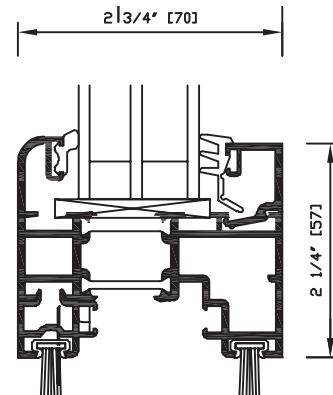

Typical Kickplate

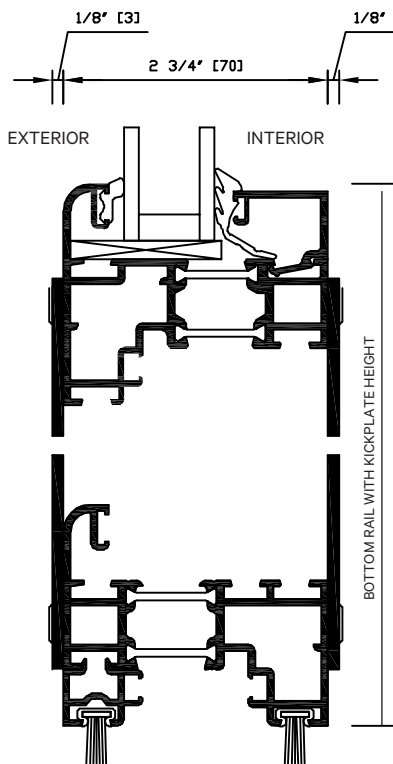

Typical Simulated Divided Lites Muntin with Spacer Between Insulated Glass (SDL)

